

L30B PRO / L35B PRO



VOLVO

TAKING PERFORMANCE, VERSATILITY TO A NEW LEVEL.

The Volvo L30B Pro and L35B Pro Compact Wheel Loaders are packed with performance to give you a highly productive, highly versatile machine. Both models allow you to do more with less effort. Test one and you'll discover a compact wheel loader that brings efficiency and performance to a new level.

The L30B Pro and L35B Pro have efficient direct injection Volvo diesel motors that are high on performance output and low on fuel consumption, saving you money on every job. And while you'll be able to move plenty of earth, you won't be a disruptive environmental force because of the low emission exhaust/gas ratio that meets new ISO 8178 standards.

Easy on, easy off differential locks keep the operator in control at all times. One hundred percent operator selectable front and rear axle differential locks give optimum traction on adverse terrain and help keep all wheels turning at the same speed.

The separate working and steering hydraulic pumps raise performance and provide faster work cycles. Quick steering actions won't impact performance because the independent hydraulic system always maintains the same speed when working and steering at the same time. The smoothness of the hydraulic control valve provides precise control during all hydraulic operations.

You'll also be able to go where other units can't because of heavy-duty portal axles that feature superb ground clearance. Super strong front and rear axles transmit optimal drive torque to the wheels, providing increased traction in the roughest conditions.

Both units have a highly agile frame that has an articulating/oscillating joint, helping you reach tight areas. The compensation provided by the front and rear frame oscillation helps the operator enjoy comfort, stability and superior steering on all surfaces, including uneven terrain.

The beveled lower side counterweight allows both units to operate up or down extremely steep slopes, giving the operator use of a versatile machine built for a variety of job sites and conditions.



- Big on output, low on fuel to save money on every job.



- Operator selectable differential locks provide optimal traction.



- Separate hydraulic pumps provide fast cycle times.



- Superb ground clearance, drive torque and traction.
- Control valve for smooth, precise hydraulic control.



- Articulating frame for work in tight areas.
- Versatile machine operates on steep slopes.

THE ABILITY TO COMFORTABLY TAKE ON ANY JOB.

With an extensive selection of attachments available, the Model L30B Pro and Model L35B Pro can help you to do more than you ever thought possible. You'll be able to tackle the various jobs in the comfort and safety of a deluxe cab that makes your work much easier and your workday much shorter.

Changing attachments is fast and easy with the standard hydraulic quick coupler that lets you get connected right from the operator's seat. And there are a wide variety of available attachments, including forks, buckets, material handling arm, sweeper and a snowplow. There are also adapters available which allow attachments from other manufacturers to fit on the Z attachment carrier, providing even greater versatility.

Unleash the machine's power and potential with the Z-bar loader linkage, which features exceptional breakout force and parallel lift-arm action. Dual lift cylinders boost power for optimum lift height and fast cycle times. And because the Z-bar loader linkage is long and narrow, the operator always has a clear view of the loading fork, this is also the case for the TP-loader linkage available on the L35B pro.

Both units feature narrow ROPS columns, wide windows and a rounded rear section to provide the operator with 360° of visibility to simplify operation and enhance safety.

The cab features large anti-slip steps and handrails for safe access from both sides of the machine so the operator always has three points of contact. Inside the cab, you'll find one of the most spacious operator stations in its category, providing exceptional comfort for increased productivity. Easy-to-read controls put you in command of an operator-friendly workhorse. And you'll be able to instantly monitor all functions because of well-positioned control gauges.

An ergonomic joystick provides effortless handling of multiple functions, including lift, lower, dig, dump, drive direction and differential locks. The enclosed, cab features climate control systems, and an adjustable operator's seat and steering column which help reduce fatigue.



- Hydraulic quick coupler for fast attachment changes.



- A wide variety of attachments available including material handling arm.



- 4 in 1 bucket.



- Sweeper.



- Easy-to-read dashboard puts you in control.
- Spacious cab offers comfort and visibility.
- Z-bar linkage provides excellent visibility of attachments.
- Anti-slip steps provide easy, safe cab access.
- Ergonomic control for multiple functions.



ENDURING QUALITY THAT'S ALWAYS EASY TO MAINTAIN.

Along with performance and versatility, the Volvo L30B Pro and L35B Pro Compact Wheel Loaders provide superb quality and serviceability. More care and quality is built in for maximum uptime. When repairs are needed, both units offer easy-access serviceability to get you back to work faster.

Every Volvo machine features high quality assembly and quality control and because Volvo uses up-to-date products from suppliers, you're guaranteed the highest quality and reliability.

The durable bucket teeth are built tougher than ever for improved digging ability. You can handle the toughest workloads and feel the power of the direct injection diesel engine and sturdy robot-welded frame. Adjustable fenders give you added flexibility and wheel coverage, regardless of tire size.

Both units offer easy access for routine or extensive service. Under the lift-up bonnet, you'll find transverse-mounted service points and simplified access to the air, oil, fuel and hydraulic filters. Longer service intervals help reduce maintenance costs and keep you on the job, instead of under the engine hood. Both machines feature long-life timing belts and a long-lasting standard water separator to ensure optimal performance, minimal wear and maximum uptime for the life of the machine. Daily servicing is easy with ground-level access for fuel fill and grease points.

The hydraulic hoses and electrical cables are guided through the middle of the central articulation/oscillation joint for maximum protection. This superior design helps avoid expensive machine downtime and repairs.

The units are also built for safety, with ROPS/FOPS certified cabs, seatbelts, hydrostatic braking system, front and rear work lights and a sound insulated hood that protects operator hearing. It all adds up to a safer working environment for both the operator and those working near the unit.



- Protected hoses and cables to avoid expensive downtime.



- Long service intervals and easy-access filters.



- Quality components and construction ensure long life.



- The bucket teeth provide quality and power.
- Easy service access to the engine compartment.



- Long lasting hydraulic filters, to reduce costs.
- ROPS/FOPS certified cab for safe operation.

SPECIFICATIONS

Engine

Volvo in-line 4-cylinder, 4 stroke, direct injection diesel engine with turbocharging, oil/air cooled.

Air cleaning:

1. Paper filter with indicator in cab / 2. Safety filter

	L30B Pro	L35B Pro
Engine	D3DCDE2	D3DCEE2
Gross power @	2300 r/min	2600 r/min
SAE J1995	52 kW - 71 hp	57 kW - 77 hp
Net power @	2300 r/min	2600 r/min
SAE J1349 - DIN ISO 1585	50 kW - 68 hp	55 kW - 75 hp
Max torque @	1600 r/min	1600 r/min
SAE J1995 netto	241 Nm	241 Nm
DIN ISO 1585	241 Nm	241 Nm
Cubic capacity	3,11 l	3,11 l

Electrical system

	L30B Pro	L35B Pro
Voltage/Battery capacity	12 V - 88 Ah	12 V - 88 Ah
Alternator rating	1120 - 80 W/A	1120 - 80 W/A
Starter motor output	2,2 kW	2,2 kW

Drivetrain

Transmission: hydrostatic transmission, full power shift under load, both when changing direction (forward and reverse) and between ranges. Maximum drawbar force can be achieved in all ranges. "Inch/brake pedal" for variable machine speed control and power transfer to bucket hydraulics at constant engine rpm. Multi-function lever for change of direction, differential lock and use of the servo-control.

Axles: all-wheel drive by two rigid portal axles.

Differential locks: hydraulically actuated 100% differential locks in both axles.

Frame: solid front and rear frame, robot-welded. Articulating oscillating joint for optimum manoeuvrability and traction.

	L30B Pro	L35B Pro
Oscillation at wheel, max.	250 mm	270 mm
Track	1482 mm	1532 mm
Angle of oscillation	±10°	±10°
Tire /Rim size	365/80R2 /11x20	405/70R2 /13x20

	(Standard)	(High Speed)
Maximum speed		
1st range forward/reverse	6 km/h	8 km/h
2nd range forward/reverse	20 km/h	30 km/h

Brake system

Service brake: reliable dual braking system, acting upon all four wheels.

1. Wear-free, hydrostatic inching brake
 2. Central friction brake, actuated via "inch/brake pedal". First stage of pedal application actuates the inching facility, the last third of pedal application applies the central friction brake.
- Parking brake: central drum brake, acting upon all four wheels.

Steering system

Hydrostatic steering. Central articulating-ocillating joint with damping effect.

Angle of articulation ±40°

Steering pump/gear-type pump

	L30B Pro	L35B Pro
Flow @ engine	25 l/min - 2300 r/min	29 l/min - 2600 r/min
Relief valve pressure	18,5 MPa	18,5 MPa

Cab

Instrumentation: All important information is centrally located in the operator's field of vision.

Hydraulic system

Thermostatically controlled oil circuit with integrated cooling system.

Hydraulic control valve: Servo-controlled, double acting control valve with three spool system, with primary and secondary pressure valves.

1. Lifting function / 2. Tilting function / 3. Additional function for hydraulic QC.

Unlock, neutral, lock. Preparation for operating hydraulic attachments with this function is available as an option.

Hydraulic oil filter: Combined suction and return-filtration cartridge with a 10 µm filter. The filter can be replaced without emptying the hydraulic oil tank.

Hydraulic pump / gear type-pump

	L30B Pro	L35B Pro
Flow @ engine	55 l/min - 2300 r/min	73 l/min - 2600 r/min
Relief valve pressure	25 MPa	25 MPa

Linkage

Powerful Z-bar loader-linkage. L35BPro is also available with TP linkage.



	L30B Pro	L35B Pro
Lift cylinders / Tilt cylinders	2/1	2/1
Lift time (loaded)	6,5 s	5,5 s
Lowering time (empty)	3,5 s	3,5 s
Dump time	1,5 s	1,2 s
Crowd time	2,0 s	1,5 s

Capacities

	L30B Pro	L35B Pro
Engine	10,5 l	10,5 l
Fuel tank	86,0 l	86,0 l
Front axle	12,2 l	12,2 l
Rear axle, incl. drop-box	13,5 l	13,5 l
Hydraulic tank, incl. hydraulic system	65,0 l	65,0 l

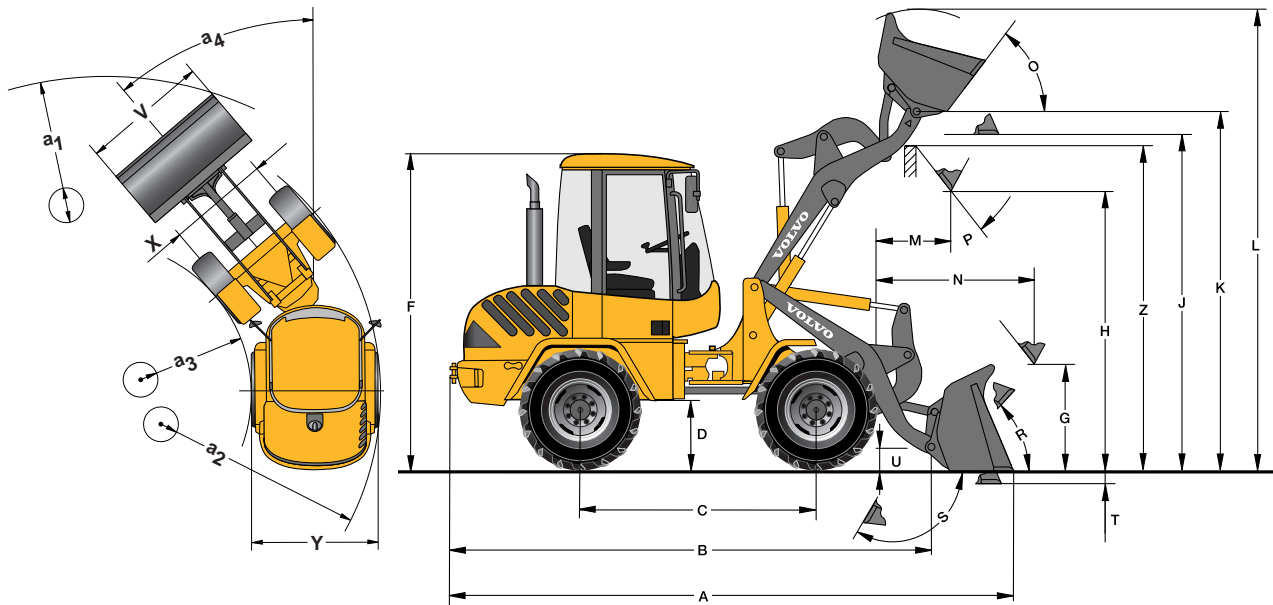
SPECIFICATIONS - L30B PRO







Data according to bucket type		General Purpose		4 in 1
L30B Pro with Z-bar linkage, Z-attachment carrier and 365/80 R20 tires				
Capacity heaped	m ³	1,0	1,1	0,9
Material density	kg/m ³	1900	1700	1900
Static tipping load, straight (ISO / DIS)	kg	4350	4250	4000
Static tipping load, full turn 40° (ISO / DIS)	kg	3850	3800	3550
Hydraulic lifting capacity, max.	kN	57,0	55,5	53,0
Breakout force	kN	61,0	53,0	53,0
A Total length	mm	5140	5240	5240
L Lift height, max.	mm	4220	4260	4130
V Bucket width	mm	1900	1900	1900
a ₁ Clearance circle	mm	8490	8550	8560
T Digging depth	mm	50	50	55
H Dump height	mm	2580	2505	2480
M Reach at max. height	mm	680	745	710
N Reach, max.	mm	1455	1525	1490
Operating weight	kg	5500	5520	5710

L30B Pro with Z-bar linkage, Z-attachment carrier and 365/80 R20 tires		
B	4340	mm
C	2150	mm
D	600	mm
F	2740	mm
G	900	mm
J	3060	mm
K	3260	mm
O	70	°
P	45	°
R	50	°
S	140	°
U	200	mm
X	1482	mm
Y	1835	mm
Z	2960	mm
a ₂	3900	mm
a ₃	2030	mm
a ₄	±40	°

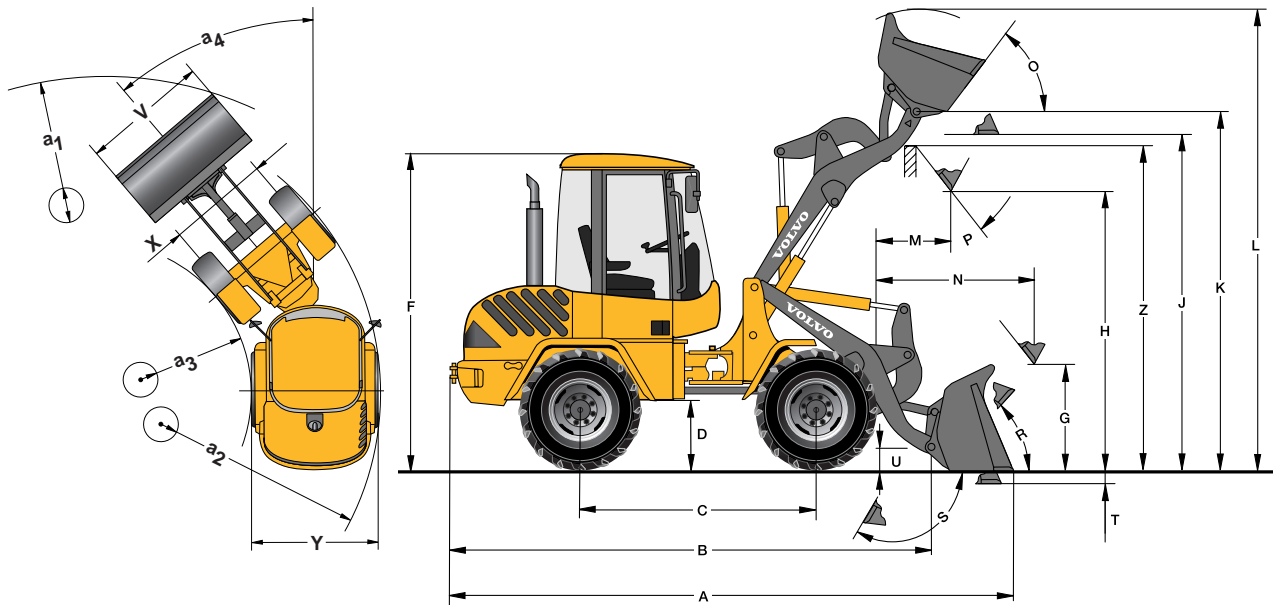

Data with loading fork		
Centre of gravity 500 mm		
Tipping load, full turn (ISO / DIS)	kg	3000
Payload according to EN 474-3, 60/80%	kg	1800/2400
Payload 80%, transport position, 40 ° full turn	kg	2500

SPECIFICATIONS - L35B PRO



Data according to bucket type		General Purpose		4 in 1
L35B Pro with Z-bar linkage, Z-attachment carrier and 405/70 R20 tires				
Capacity heaped	m ³	1,2	1,2	1,0
Material density	kg/m ³	1800	1700	1900
Static tipping load, straight (ISO / DIS)	kg	4950	4750	4450
Static tipping load, full turn 40° (ISO / DIS)	kg	4350	4200	3950
Hydraulic lifting capacity, max.	kN	61,5	59,5	58,5
Breakout force	kN	60,5	52,5	52,5
A Total length	mm	5280	5380	5380
L Lift height, max.	mm	4320	4340	4260
V Bucket width	mm	2100	2000	2000
a1 Clearance circle	mm	8760	8730	8740
T Digging depth	mm	95	95	100
H Dump height	mm	2670	2590	2570
M Reach at max. height	mm	750	810	780
N Reach, max.	mm	1570	1630	1600
Operating weight	kg	6250	6260	6440

L35B Pro with Z-bar linkage, Z-attachment carrier and 405/70 R20 tires		
B	4485	mm
C	2150	mm
D	610	mm
F	2745	mm
G	900	mm
J	3145	mm
K	3345	mm
O	66	°
P	45	°
R	50	°
S	135	°
U	200	mm
X	1532	mm
Y	1932	mm
Z	3050	mm
a ₂	3960	mm
a ₃	1980	mm
a ₄	±40	°

Data with loading fork		FEM II	FEM III
Centre of gravity 500 mm			
Tipping load, full turn (ISO / DIS)	kg	3340	3300
Payload according to EN 474-3, 60/80%	kg	2000/2500	2000/2600
Payload 80%, transport position, 40 ° full turn	kg	2500	2800

SPECIFICATIONS - L35B PRO TPZ

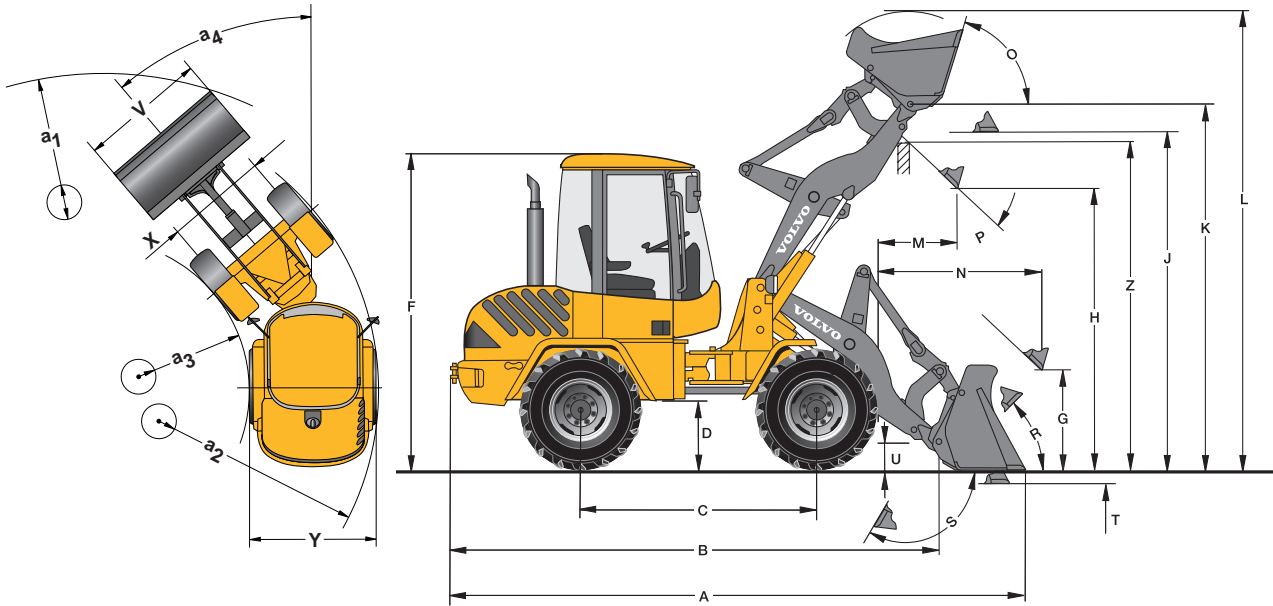





Data according to bucket type		General Purpose		4 in 1
L35B Pro with TP- linkage, Z-attachment carrier and 405/70 R20 tires				
Capacity heaped	m ³	1,0	1,2	0,9
Material density	kg/m ³	1800	1500	1900
Static tipping load, straight (ISO / DIS)	kg	4200	4150	3900
Static tipping load, full turn 40° (ISO / DIS)	kg	3700	3650	3450
Hydraulic lifting capacity, max.	kN	57,0	55,5	54,0
Breakout force	kN	62,5	54,5	59,0
A Total length	mm	5280	5380	5320
L Lift height, max.	mm	4290	4330	4200
V Bucket width	mm	2000	2000	2000
a ₁ Clearance circle	mm	8670	8730	8700
T Digging depth	mm	90	90	90
H Dump height	mm	2610	2535	2560
M Reach at max. height	mm	725	785	715
N Reach, max.	mm	1545	1605	1535
Operating weight	kg	6100	6120	6285

L35B Pro with TP - linkage, Z-attachment carrier and 405/70 R20 tires		
B	4455	mm
C	2150	mm
D	580	mm
F	2715	mm
G	900	mm
J	3100	mm
K	3350	mm
O	63	°
P	45	°
R	50	°
S	58	°
U	250	mm
X	1532	mm
Y	1932	mm
Z	3020	mm
a ₂	3960	mm
a ₃	1980	mm
a ₄	±40	°

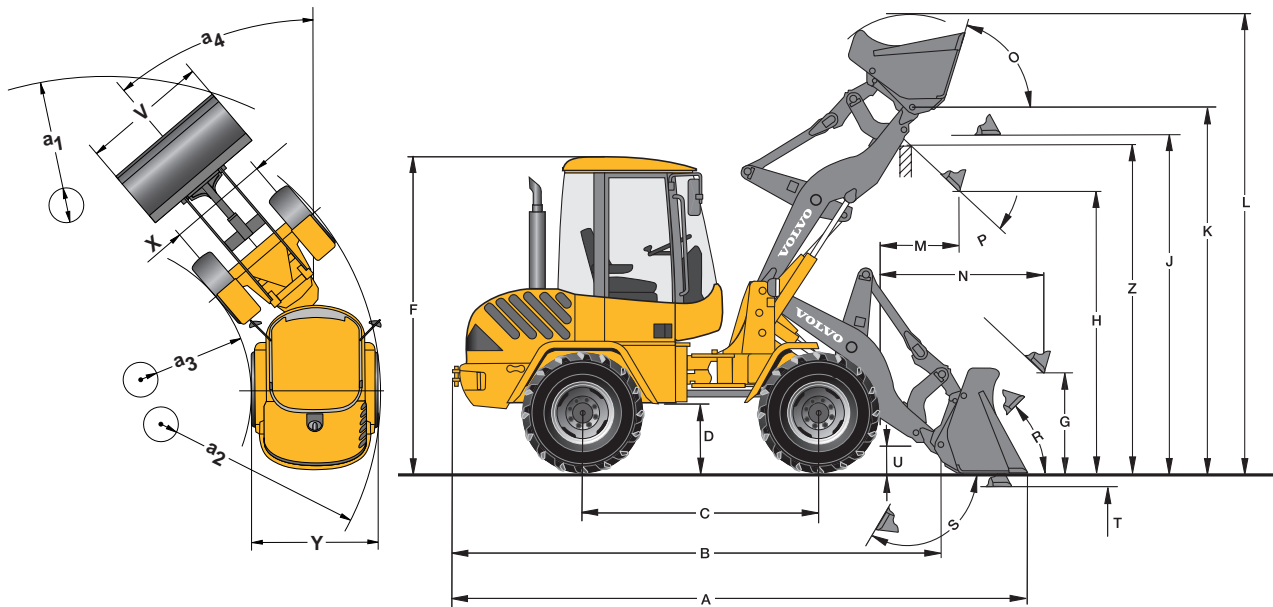
Data with loading fork		
Centre of gravity 500 mm		
Tipping load, full turn (ISO / DIS)	kg	2930
Payload according to EN 474-3, 60/80%	kg	1750/2300
Payload 80%, transport position, 40 ° full turn	kg	2500

SPECIFICATIONS - L35B_{PRO} TPV



Data according to bucket type		General Purpose		4 in 1
L35B Pro with TP- linkage, V-attachment carrier and 405/70 R20 tires				
Capacity heaped	m ³	1,0	1,2	0,9
Material density	kg/m ³	1800	1400	1800
Static tipping load, straight (ISO / DIS)	kg	4500	3900	3750
Static tipping load, full turn 40° (ISO / DIS)	kg	3600	3450	3300
Hydraulic lifting capacity, max.	kN	52,0	50,5	49,0
Breakout force	kN	54,5	48,5	51,5
A Total length	mm	5380	5480	5415
L Lift height, max.	mm	4250	4390	4260
V Bucket width	mm	2000	2000	2000
a ₁ Clearance circle	mm	8730	8800	8760
T Digging depth	mm	85	85	85
H Dump height	mm	2550	2470	2490
M Reach at max. height	mm	800	855	785
N Reach, max.	mm	1620	1675	1600
Operating weight	kg	6200	6240	6390

L35B Pro with TP - linkage, V-attachment carrier and 405/70 R20 tires		
B	4455	mm
C	2150	mm
D	580	mm
F	2715	mm
G	850	mm
J	3100	mm
K	3350	mm
O	63	°
P	45	°
R	50	°
S	58	°
U	250	mm
X	1532	mm
Y	1932	mm
Z	3100	mm
a ₂	3960	mm
a ₃	1980	mm
a ₄	±40	°

Data with loading fork		
Centre of gravity 500 mm		
Tipping load, full turn (ISO / DIS)	kg	2750
Payload according to EN 474-3, 60/80%	kg	1650/2200
Payload 80%, transport position, 40 ° full turn	kg	2500

STANDARD EQUIPMENT

Engine

Diesel engine, direct fuel injection.
Extra fuel filter.
Cold start aid.
Dry-type air filter.

Electrical system

L30B Pro : Alternator 80 A.
L35B Pro : Alternator 80 A.
Main head lights (halogen)
full/dipped/asymmetrical.
Working lights (2 front/1 rear, right).
Parking lights.
Rear lights.
Brake lights.
Direction indicators.
Hazard warning lights.
Reversing lights.
Cab lighting.

Instrumentation & controls:

Multi-function lever
12 Volt accessories socket
Horn
Hazard warning switch
Safety start.
Analog LED-information for:
Fuel level
Engine temperature
Drive system oil temperature.
LED-illuminated symbols (colour-coded) for:
Direction (forward/reverse)
Indicators (left/right)
Pre-heater
Main beam
Differential locks.
LED-illuminated symbols (red) with
acoustic signal for:
Parking brake
Air filter restriction
Drive system oil temperature

Engine temperature
Engine oil pressure
Battery charging
Return filter.
Touch pad with symbols and integrated
LEDs for:
Parking lights
Working lights (front/rear)
Windscreen wiper (rear)
Rotating beacon
Boom suspension system
Locking and activation of Volvo-
attachment carrier (TPV)
Activation of directional change on
joystick.
Digital LED display activated by dual
function keys for:
Entry and retrieval of operating
information
Anti-theft function control.

Drivetrain

Hydrostatic drive.
Operator-selected 100% differential locks
Tires:
L30B Pro 365/80 R20
L35B Pro 405/70 R20.

Cab Exterior

ROPS/FOPS-cab with flexible mountings.
Walk-through cab.
Lockable doors.
All-round tinted safety glass.
Windscreen wiper (front/rear).
Windscreen washer (front/rear).
Sliding window in the left door.
Door stops.
External rear view mirrors (right/left).

Cab Interior

4-way adjustable operator's seat.
Adjustable steering column.
Seat belt.

Sunvisor.
Heater with air-filter and defroster
(front/rear).
Cab ventilation.
Preparation for an optional air-conditioner.
Storage box in the cab.

Hydraulic system

Gear-type pump.
Control valve three-spool system.
3rd hydraulic circuit.

Working Equipment

Bucket level indicator.
Hydraulic quick-change attachment carrier.

Carriage Body

Fenders front/rear.
Lockable engine hood.
Vertical exhaust.
Towing device.
Lifting eyes.

Service and maintenance

Tool kit.
Wheel nut wrench.

International Standards for Machines and Production

Quality: DIN/ISO 9001.
Safety: CE - Criterion.
Machine guide-lines 98/37/EC
ROPS ISO 3471
FOPS ISO 3449.
Operating weight ISO 7131.
Tipping load / Payload: ISO / DIS 14397-1.
EMV (Electromagnetic Compatibility)
89/336/EEC plus supplement.
Environment: DIN/ISO 14001.
Sound regulation: 2000/14/EC.
German environmental seal "low noise"
RAL - UZ 53 (20 km/h version).

OPTIONAL EQUIPMENT (Standard on certain markets)

Engine equipment

Pre-heater.
Pre cleaner air filter (Turbo II).
Oilbath air filter.
Exhaust particle filter.

Cab

Handthrottle.
Hand control inch valve.
Airconditioner.

Radio.
Working light (1 rear, left).
Air suspension operator's seat.

Hydraulic system

Hydraulic coupler for 3rd hydraulic circuit.
4th hydraulic circuit.
Additional pump.

Environment

Initial filling of biodegradable hydraulic oil.
Low noise kit (L30B Pro, 30 km/h version).

Safety

Anti-theft system.
Protective guards for:
Main head lights
Working lights
Rear lights.
Rotating beacon.
Audible reverse alarm.



Volvo Construction Equipment is different. It's designed, built and supported in a different way. That difference comes from our 170-year engineering heritage. A heritage of thinking first about the people who actually use the machines. About how to help them be safer, more comfortable, more productive. About the environment we all share. The result of that thinking is a growing range of machines and a global support network dedicated to helping you do more. People around the world are proud to use Volvo. And we're proud of what makes Volvo different – **More care. Built In.**



All products are not available in all markets. Under our policy of continuous improvement, we reserve the right to change specifications and design without prior notice. The illustrations do not necessarily show the standard version of the machine.

VOLVO

Construction Equipment
www.volvoce.com

Ref No. 21 1 430 5588
Printed in Germany
Volvo, Konz

English
2004.06
CWL