

Technical Description Crawler Tractor

PR 752
Litronic®

Engine Output 243 kW/330 HP

Operating Weight 34.8 - 42.0 t/76,700 - 92,600 lb

Hydrostatic Travel Drive



LIEBHERR

The travel drive

The emission optimized engine.

The heart of the PR 752 Litronic is its sturdy, turbocharged Liebherr diesel engine with an output of 243 kW/330 HP. Liebherr diesel engines are specially made for construction machine applications insuring high operating availability. They are emission optimized and very economical through low specific fuel consumption. The low nominal engine speed increases lifetime as well as reduces noise emissions.

The hydrostatic drive.

Its performance outstrips that of conventional systems due to its constant high efficiency. Uninterrupted transfer of diesel engines output provides constant power to both tracks assuring the highest performance even when travelling slopes.

The speed selection switch integrated into the travel joystick lever allows the operator to select from 3 different speed ranges. Thus the working speed can be optimally adapted to each respective application.

In addition, the PR 752 Litronic has a parking and safety brake system installed in the final drive entirely separated from the travel drive.

Cooler.

The large mesh cooler allows small particles to escape so that cooler clogging is minimized even during extremely dusty applications ensuring sufficient amounts of cooling air.

Litronic control.

The PR 752 travel drive is controlled and monitored through the Litronic system. It constantly monitors the current machine condition and is activated by deviations from normal settings in the travel drive. The integrated electronic engine speed sensing control protects the machine against overload. Exact straight travel is ensured via Litronic.





Climbing ability.

The hydrostatic travel drive gives the PR 752 a very low center of gravity. This lends the machine excellent climbing ability and maneuverability.

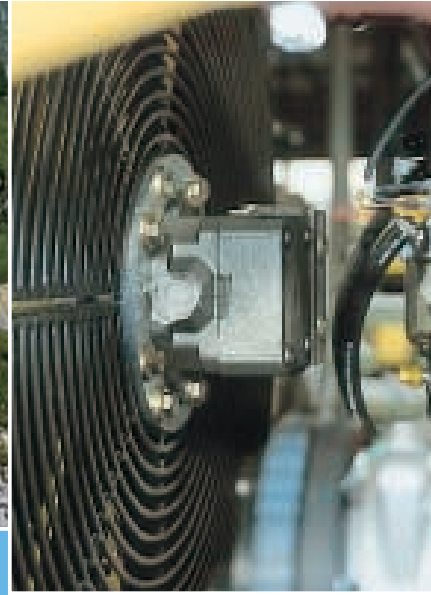

Cooler.

Water cooler and intercooler are front mounted with a hydraulically driven fan. The separate oil cooler is located at rear of the machine.



The track

Innovative track frame technology.

The PR 752 Litronic has a specially developed track frame for all kinds of applications.

Sturdy construction was an important factor when designing the track frame. The entire track frame absorbs push arm loads. This pressure is dispersed through a massive pivot shaft assembled with the frame. The track frame has oscillating suspension.

The cushioned suspension reduces shock loads to the operator and the machine.

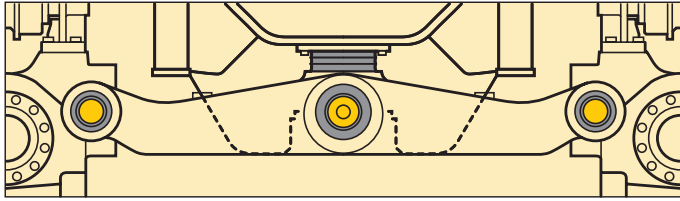

Cushioned track frame suspension.

The machine achieves optimal power transfer with its balanced center of gravity. Large ground clearance yields full functionality even in extreme terrain.

The long lifetime of the PR 752 Litronic track frame is achieved through the general constructive advantages of the standard track frame and its great wear resistance.



Track frame oscillation.

The track frame has oscillating suspension to ensure optimal drawbar pull.





Powerful track frame construction.

The entire track frame absorbs entering shock load from the underfooting.

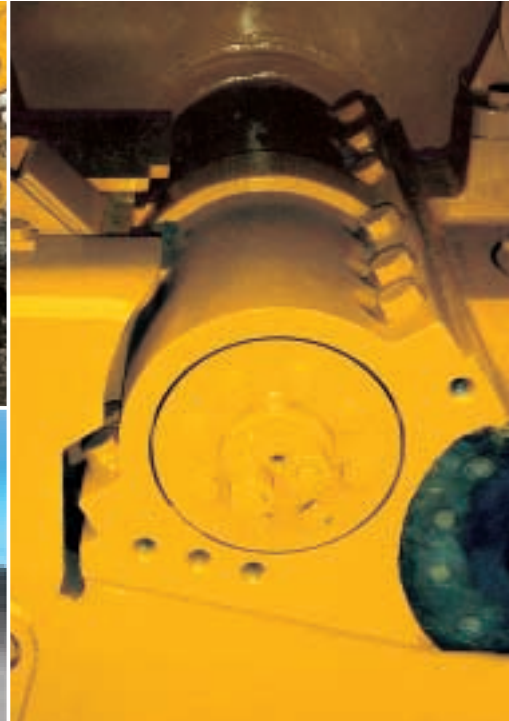

Pivot shaft.

Entering loads are dispersed via a massively cushioned pivot shaft into the main frame.



The attachments

The working attachments.

Sturdy working attachments are especially important for overall usage of the machines in the PR 752 class. In order to ensure high operating availability, the front as well as rear attachments are built especially strong.

Attachment hydraulics.

The attachment hydraulics have load sensing control resulting in optimal precise steering of the attachment and reduced fuel consumption and protects the system against thermic overload.

The front attachments.

The L-design of the push arm gives it extreme rigidity and ensures constant exact settings between the push frame and blade.

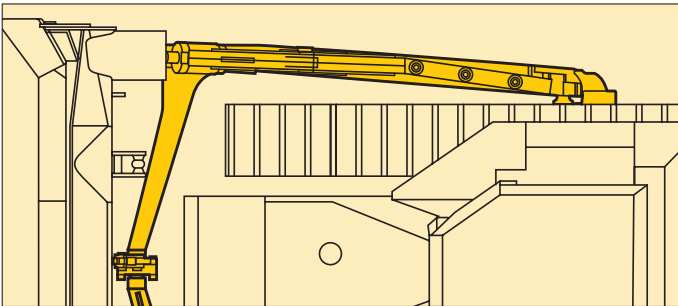

L-design push arm.

The hydraulic pipes to the tilt cylinders are additionally protected to ensure high operating availability.

The Liebherr dozer blades ensure optimal rolling characteristics of the material to be moved and high penetration forces through its design.

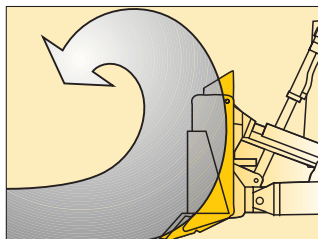

The rear attachment.

To ensure high operating availability even under the toughest conditions, the rear attachment is built especially strong. Besides various rippers, the PR 752 can also be equipped with a winch or other add-on accessories. The ripper runs parallel in order to maintain a precise rip angle. The hoist cylinders are protected with this design.



Front attachment.

Liebherr offers the right blade attachment for every application. The standard mechanical blade pitch adjustment can be optionally controlled hydraulically, which is a great advantage when operating in difficult terrain.





Ripper.

The shank of the massively constructed parallelogram ripper is visible at all times.

Working environment

Operating and maintenance friendly.

The PR 752 Litronic cab is made to meet all the demands of a modern construction machine. It offers roominess, ergonomically optimized operating controls, safety with integrated ROPS/FOPS and excellent visibility of the working attachment. To improve the operator's sitting position for ripper operation, the seat is turned 15°.

All travel drive functions are controlled through a single joystick allowing the operator to fully concentrate on the work to be done.

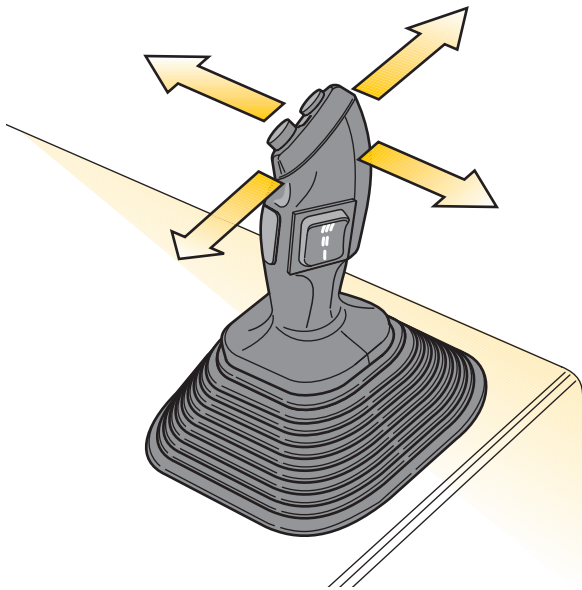

Single joystick operation.

The travel speed is regulated with the joystick, by pushing the lever forwards (forward travel) or backwards (reverse travel). The further the joystick is pushed, the higher the speed. By pulling the joystick back, the machine can be slowed or stopped gently. Curve travel is accomplished by pushing the lever to the side.

To control the machine's precise movements, the operator can choose between three speed ranges.

All operating conditions are monitored by Litronic. When critical values are reached, the operator is informed optically.

All of the PR 752 Litronic maintenance points are easily accessible. Long maintenance intervals and short maintenance times result in ease of maintenance.



Engine compartment.

All maintenance points are accessible from one side ensuring short maintenance times and ease of maintenance.



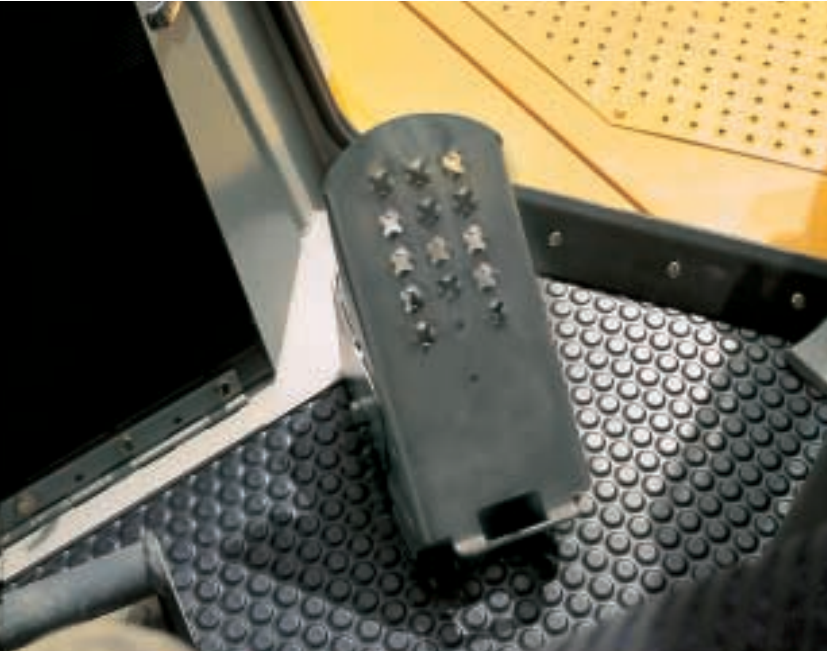

Inch-/Brake pedal.

Activation of this pedal allows the operator to reduce the speed steplessly to 0 km/h, as well as to activate the emergency brakes.



Tilted cab.

The tiltable cab gives optimal accessibility to the travel drive.



Technical Data



Diesel Engine

Liebherr-Diesel Engine	D 9406 TI-E
Rating per ISO 9249	243 kW (330 HP) at 1800 RPM
Displacement	13.0 l (794 cu.in.)
Bore/stroke	135 mm/150 mm (5.31/5.91 in.)
Design	6 cylinder V-engine, direct injection, intercooled, turbocharged mounted at front
Injection	direct fuel injection with in-line injection pump, mechanical governor
Fuel filter	pre-cleaner with water separator and micro filters
Lubrication	pressurized lube system with full flow filter and integrated oil cooler, deep oil pan for inclinations, engine lubrication to an inclination of up to 45° to each side
Air cleaner	dry-type air cleaner with pre-cleaner and dust ejector, main and safety element
Operating voltage	24 V
Alternator	80 Amp.
Starter	9 kW (12 HP)
Central fuse box	40 A
Batterie	170 Ah



Travel Drive

Design	closed-loop hydrostatic drive, each track is driven independently
Pump flow	max. 425 l/min (112.2 gpm) each pump
Max. pressure	setting 420 bar (6090 PSI)
Travel speed	0 – 11 km/h (0 to 6.8 mph) infinitely variable, forward and reverse
Steering	hydrostatic
Service brake	hydrostatic
Parking/emergency brake	automatic multi disc brake in final drives
Cooling system	hydraulic oil cooler with separate cooling circuit with gear pump and right side mounted cooler
Filter system	cartridge micro filters in the cooling circuit
Final drive	double reduction planetary gear

Drawbar pull kN

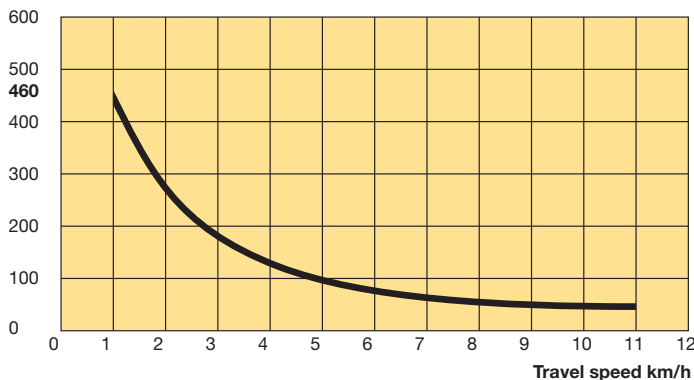

Track frame

Design	maintenance-free tractor type track frame
Mount	elastic components at a separate pivot shaft and an oscillating equalizer bar, oscillation $\pm 3^\circ$
Chains	sealed and oil lubricated, track chain tension via grease tensioner and spring unit, single grouser pads ESS
Chain links	44
Sprockets	3 replaceable segments
Track rollers	7
Carrier rollers	2



Travel control

1 Joystick lever	with electronic control for all travel functions: travel direction, speed, steering and counterrotation
Speed range 1	0 – 4.0 km/h (0 – 2.5 mph) / reverse 4.8 km/h (3.0 mph)
Speed range 2	0 – 6.5 km/h (0 – 4 mph) / reverse 7.8 km/h (4.9 mph)
Speed range 3	0 – 11.0 km/h (0 – 6.8 mph)
Electronic engine speed sensing control	electronic regulation assures a constant balance between travel speed and necessary drawbar pull through engine speed sensing avoiding engine overload
Straight line travel	electronically controlled
Parking/emergency brake	automatically applied after the joystick lever is put in neutral position
Safety lever	inactivates complete travel and working hydraulic circuit and automatically activates parking brake
Emergency shut off	push button on instrument panel immediately activates parking and emergency brake
Inch-/Brake pedal	for reduction of travel speed to 0 km/h with integrated braking function



Implement Hydraulic

Hydraulic system	load sensing proportional pump flow control, variable flow swash plate piston pump and pressure compensation
Pump flow	max. 336 l/min (88.7 gpm)
Pressure limitation	setting 200 bar (2900 PSI)
Control valve	with 4 circuits
Filter system	return filter with magnetic rod in hydraulic tank
Control	single servo-assisted joystick lever for blade hoist and tilt functions, electrically controlled blade float and quick drop



Attachments

Front	semi-U-blade, U-blade or mechanical angled blade with tilt
Rear	ripper, hydraulic winch or drawbar
Pivot points	maintenance-free, with hardened and polished pins and bushings



Operator's Compartment

Cab	resiliently mounted, with integrated ROPS (ISO 3471) and FOPS (ISO 3449), can be tilted with hand pump to 40° to the rear for accessibility to machine components, diagonally arranged doors, all around safety glass
Operator's seat	fully adjustable, suspended seat, adjustable to operator weight
Instrument panel	comprehensive instrument panel on the right side of the operator's seat
Ventilation	pressurized filtered air ventilation, 3stage blower, 8 air nozzles, sliding windows left and rear
Heater	hot water heater
Sound level at operator's ear	82 dB(A) on job location, conforms to ISO 6396:1992



Refill Capacities

Fuel tank	610 l (161 gal)
Cooling system	68 l (18 gal)
Engine oil	24 l (6.3 gal)
Splitterbox	6 l (1.6 gal)
Hydraulic tank	230 l (60.7 gal)
Final drive, each	21 l (5.5 gal)

Basic Machine

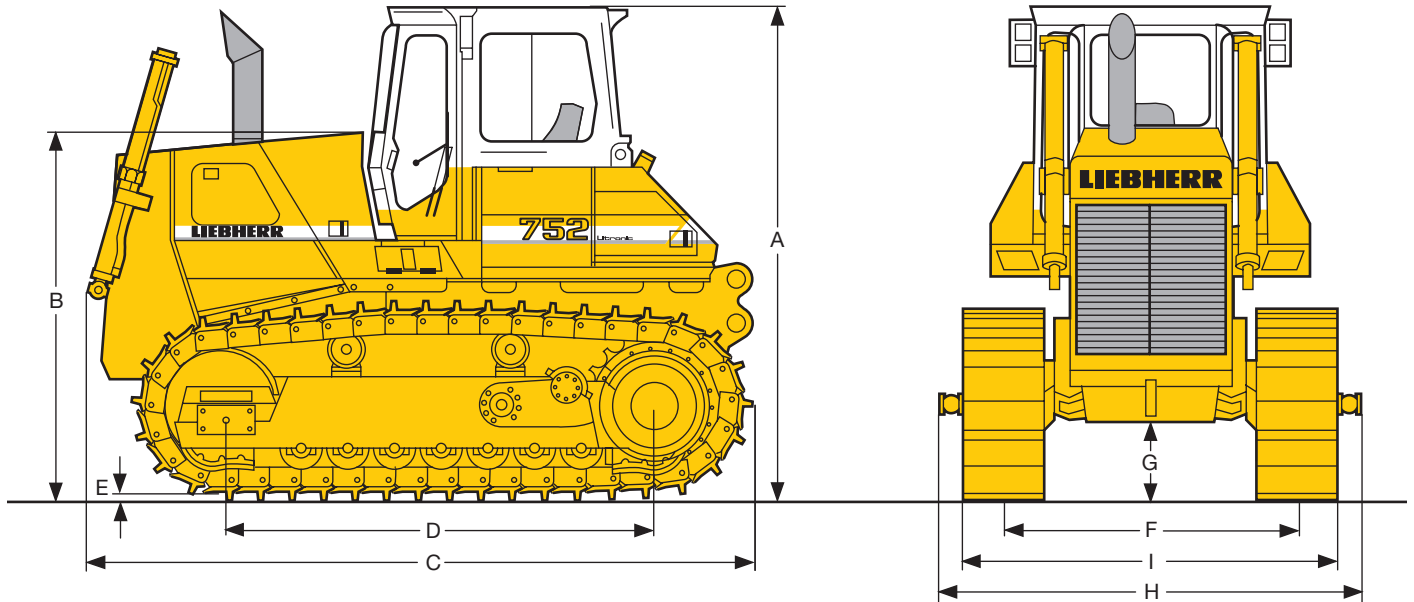

PR 752 ft-in/mm

Dimensions

A	Height over cab	11'11"/3,640
B	Height over engine cover	8'11"/2,725
C	Overall length without attachment	16'0"/4,885
D	Distance idler/sprocket center	10'5"/3,174
E	Height of grousers	3.3"/84
F	Track gauge	7'2"/2,180
G	Ground clearance	2'1"/625
H	Total width over frame mounting trunions	10'4"/3,145
I	Overall width with	
	Pad size 22"/560 mm	9'/2,740
	Pad size 24"/610 mm	9'2"/2,790
	Pad size 28"/711 mm	9'6"/2,891
Ground contact area:		
	trackpad-width 22"/560 mm	5.50 sq.in./3.55 m ²
	trackpad-width 24"/610 mm	5.99 sq.in./3.87 m ²
	trackpad-width 28"/711 mm	6.97 sq.in./4.50 m ²

Front Attachment

Semi-U-Blade with tilt

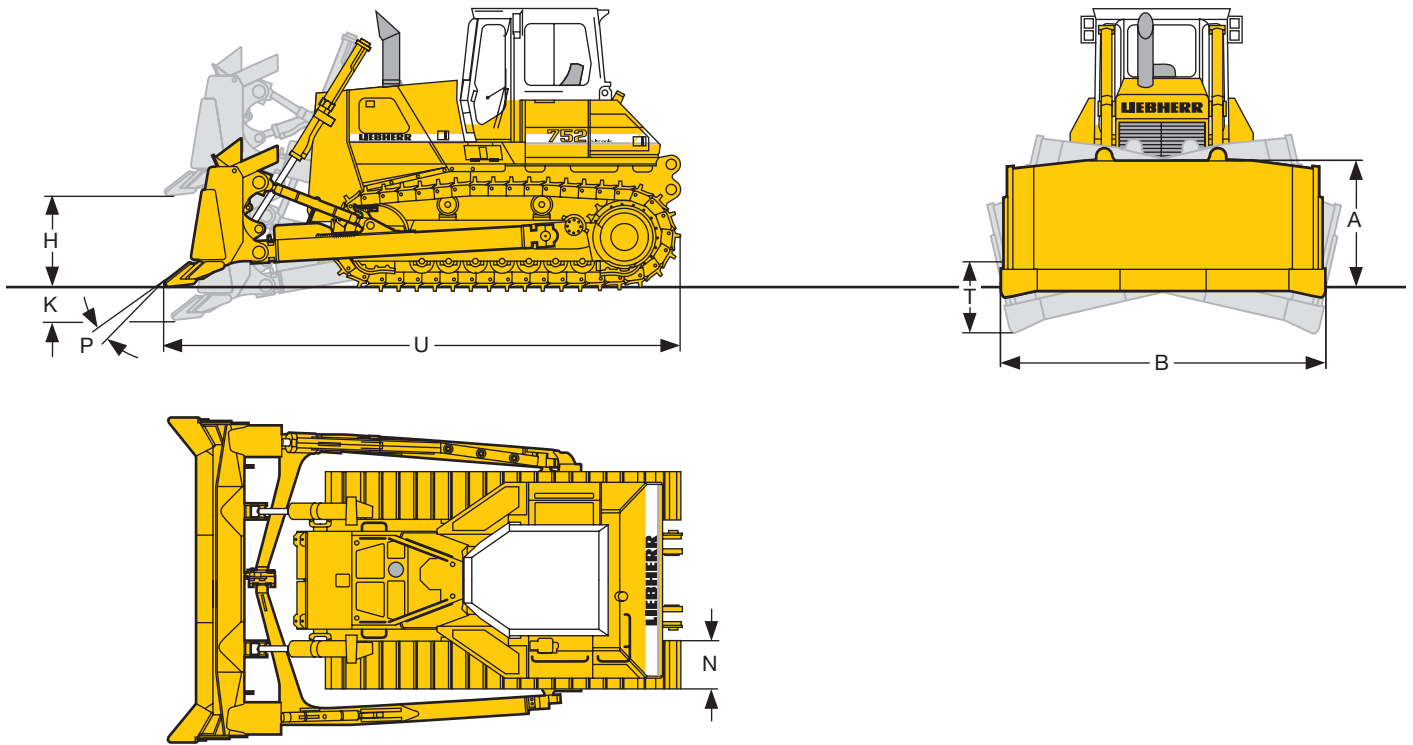

PR 752

Blade capacity 12.48 cu.yd/9.54 m³

Dimensions

	ft-in/mm
A Height of blade	5'5"/1,650
B Width of blade	13'9"/4,200
H Lifting height	4'7"/1,400
K Depth below ground	1'10"/570
P Max. blade pitch	10°
T Max. tilt	3'3"/1,000
U Overall length with blade straight	21'1"/6,415
N Trackpad width	22"/24"/28"/560/610/711

Operating Weights

	lbs/kg
Basic machine with blade and trackpads 22"/560 mm	76,778/34,820
and trackpads 24"/610 mm	77,296/35,055
and trackpads 28"/711 mm	78,333/35,525

Ground Pressures

	PSI/kg/cm ²
Basic machine with blades and trackpads 22"/560 mm	13.94/0.98
and trackpads 24"/610 mm	12.94/0.91
and trackpads 28"/711 mm	11.23/0.79

Front Attachment

U-Blade

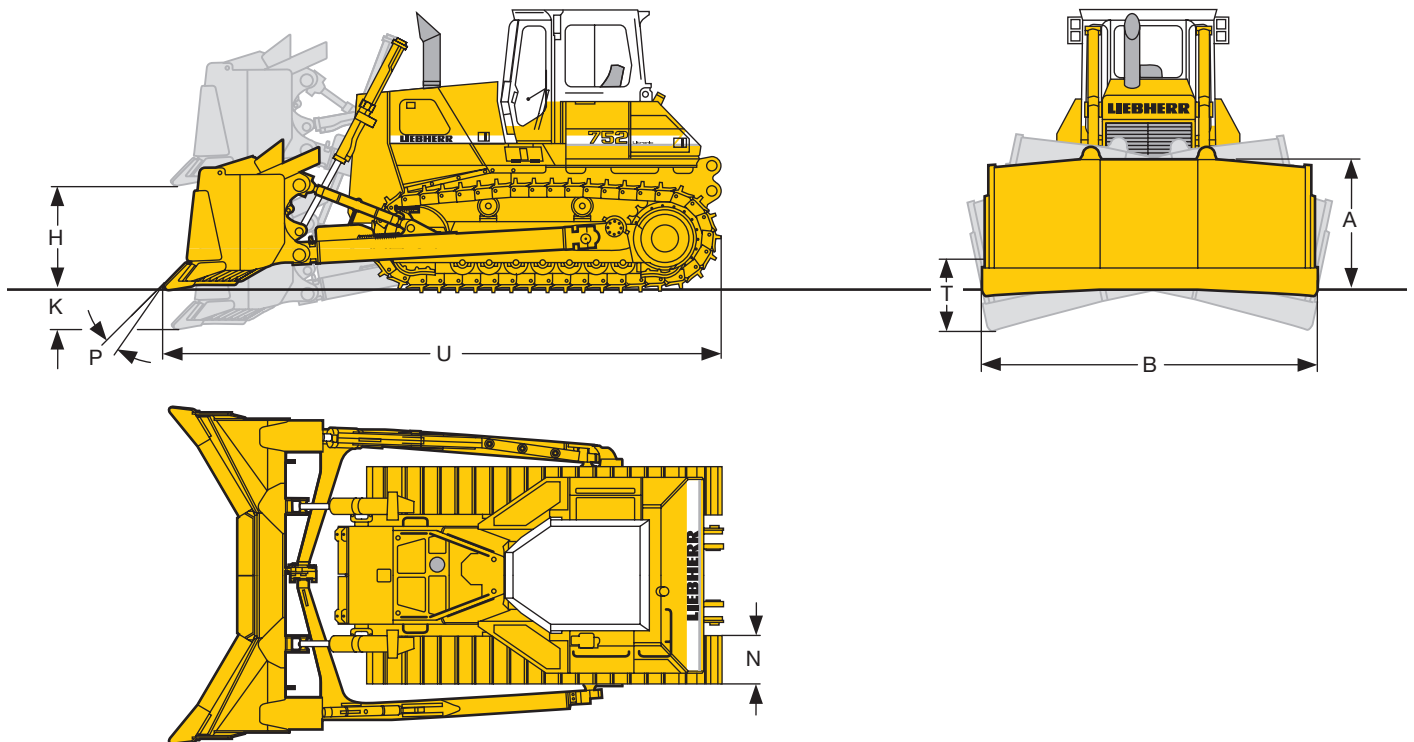

PR 752

Blade capacity	15.3 cu.yd/11.7 m ³
Dimensions	ft-in/mm
A Height of blade	5'5"/1,650
B Width of blade	14'2"/4,325
H Lifting height	4'7"/1,400
K Depth below ground	1'10"/570
P Max. blade pitch	10°
T Max. tilt	3'4"/1,025
U Overall length with blade straight	22'8"/6,915
N Trackpad width	22"/24"/28"/560/610/711

Operating Weights	lbs/kg
Basic machine with blade	
and trackpads 22"/560 mm	78,498/35,600
and trackpads 24"/610 mm	79,016/35,835
and trackpads 28"/711 mm	80,053/36,305
Ground Pressures	PSI/kg/cm ²
Basic machine with blade	
and trackpads 22"/560 mm	14.22/1.00
and trackpads 24"/610 mm	13.22/0.93
and trackpads 28"/711 mm	11.38/0.80

Front Attachment

Angle Dozer Blade

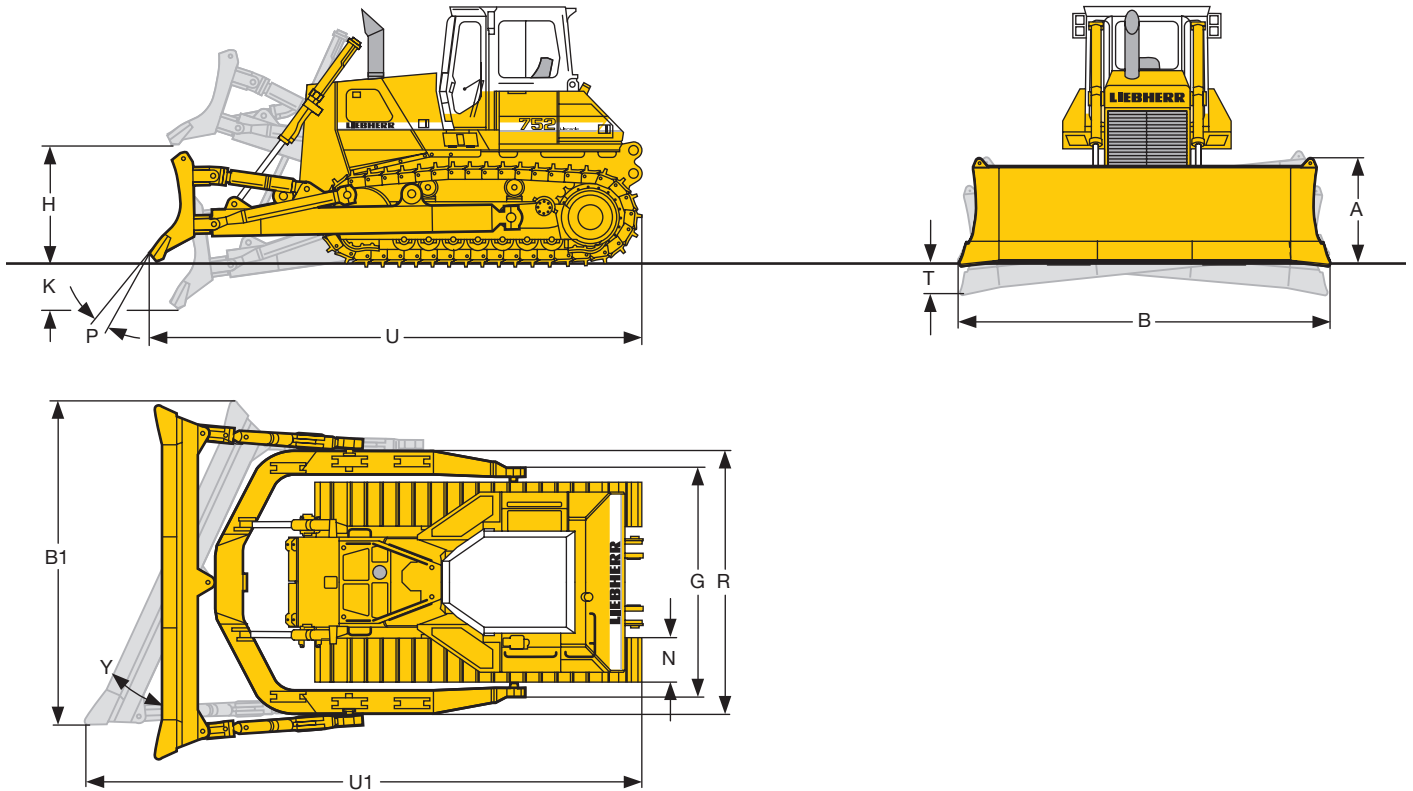

PR 752

Blade capacity	8.24 cu.yd/6.3 m ³
Dimensions	ft-in/mm
A Height of blade	4'3"/1,300
B Width of blade	16'6"/5,030
B1 Transport width	15'2"/4,612
H Lifting height	5'1"/1,558
K Depth below ground	2'2"/670
P Max. blade pitch	10°
Y Blade angle	± 25°
T Max. tilt	2'10"/851
G Width over frame mounting trunions	10'4"/3,145
R Width over C-frame	11'5"/3,480
U Overall length with blade straight	22'/6,705
U1 Overall length with blade angled	25'1"/7,643
N Trackpad width	22"/24"/28"/560/610/711
Operating Weights	lbs/kg
Basic machine with blade and trackpads 22"/560 mm	78,972/35,815
and trackpads 24"/610 mm	79,490/36,050
and trackpads 28"/711 mm	80,527/36,520
Ground Pressures	PSI/kg/cm ²
Basic machine with blade and trackpads 22"/560 mm	14.36/1.01
and trackpads 24"/610 mm	13.22/0.93
and trackpads 28"/711 mm	11.52/0.81

Rear Attachment

Ripper

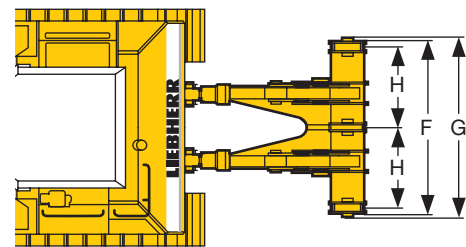
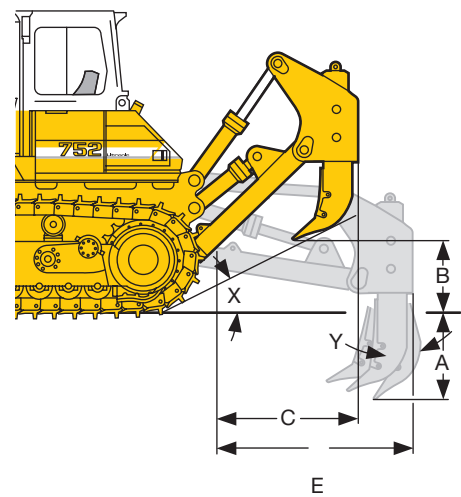
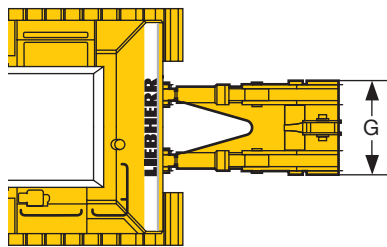
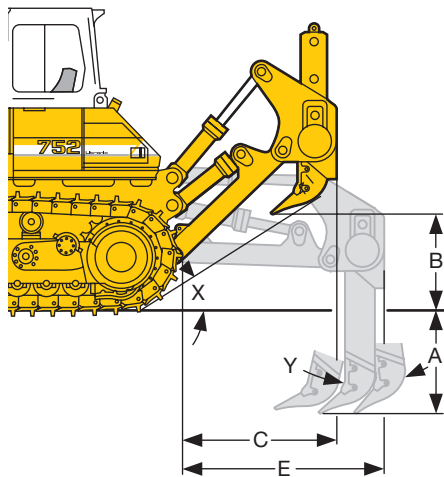

Parallelogram Single Shank

Features

Parallelogram ripper with hydraulic pitch adjustment and hydraulic pin puller
Ripper tips: ESCO

Dimensions

	ft-in/mm
A Max. penetration	3'11"/1,200
B Max. clearance under tip	3'3"/1,000
C Overall length, raised position	6'2"/1,880
E Overall length, lowered position	7'10"/2,390
G Overall beam width	4'4"/1,330
X Slope angle	30°
Y Shank adjustment angle	30°

Weight

	lbs/kg
Ripper complete	9,713/4,405

Parallelogram Multi-Shank

Features

Parallelogram ripper with hydraulic pitch adjustment
Ripper tips: ESCO

Dimensions

	ft-in/mm
A Max. penetration	2'7"/790
B Max. clearance under tip	3'1"/945
C Overall length, raised position	6'2"/1,880
E Overall length, lowered position	7'10"/2,390
F Ripping width	7'6"/2,280
G Overall beam width	8'2"/2,435
H Distance between shanks	3'7"/1,100
X Slope angle	29°
Y Shank adjustment angle	30°

Weight

	lbs/kg
Ripper complete	12,128/5,500

Equipment



Basic machine

	s	o
Exhaust catalyst		
Tow switch	•	
Towing hitch rear	•	
Towing lug front	•	
Forestry equipment		
Woodchip handling equipment	•	
Coal handling equipment	•	
Landfill equipment	•	
Battery compartment lockable	•	
Filling with environmental friendly oil	•	
Filling with oil SAE 10	•	
Filling with oil SAE 30	•	
Tank guard complete		
Tank guard bottom		•
Refuelling pump electrical		•
Belly pans heavy duty	•	
Fire suppression system engine compartment		
Connector external electric power		
Cold start device ether		
Cold start device glow plug	•	
Radiator coarse mesh	•	
Radiator guard 2-piece, hinged	•	
Liebherr Diesel engine	•	
Fan – hydraulically driven	•	
Fan guard	•	
Engine doors perforated	•	
Engine doors hinged, lockable	•	
Lugs for crane lifting	•	
Platform rear		•
Special paint		•
Settling pond equipment		
Fuel water separator	•	
Fuel water separator with electric heater	•	
Air filter dry-type, dual step	•	
Wear guard for radiator		•
Precleaner with automatic dust ejector	•	
Preheater for engine electric		
Tool kit in batteries compartment	•	



Travel drive

	s	o
Parking brake automatic	•	
Function control automatic	•	
Control – single lever	•	
Load limit control electronic	•	
Travel control electronic	•	
Travel control 3-speed	•	
Hydrostatic travel drive	•	
Emergency stop	•	



Undercarriage

	s	o
Track shoes extreme service (ESS)	•	
Track frame closed	•	
Sprocket segments bolt-on	•	
Master link 2 piece	•	
Track shoes with relief holes		•
Tracks oil lubricated	•	
Track guide center part		•
Track guard		•
Undercarriage extended		
Undercarriage low ground pressure		
Undercarriage standard	•	
Track frames oscillating +/- 3°	•	
Sprocket segments with recesses		•



Electrical system

	s	o
Starter motor 9 kW	•	
Working lights rear 2 units	•	
Working lights front 2 units	•	
Battery main switch electric	•	
Batteries, heavy duty cold start	•	
On-board system 24 V	•	
Alternator 80 A	•	
Back-up alarm		•
Beacon		
Horn	•	
Start lock electronic		•
Lights additional rear 2 units		•
Lights additional on lift cylinders		•
Lights additional on engine hood		•



Operator's cab

	s	o
Stowing box	•	
Armrest adjustable	•	
Ash tray	•	
Rear mirror outside left		
Pressurizer with air filter	•	
Operator's seat 6-way adjustable	•	
Operator's seat air suspended		•
Fire extinguisher		•
Dome light	•	
Coat hook	•	
Air conditioner	•	
FM radio		•
Radio installation kit		•
ROPS-canopy		•
ROPS/FOPS-cab sound suppressed	•	
Rear mirror inside	•	
Windscreen washer with interval function		
Windscreen wipers front, rear, doors	•	
Sliding windows	•	
Protective grids for windows		•
Safety glass tinted	•	
Sun blinds	•	
Extra cab heater		•
Cabin heater warm water	•	



Instruments - Indicators

	s	o
Battery charging	•	
Hour meter	•	
Electronic control	•	
Speed range	•	
Hydraulic oil temperature	•	
Engine oil pressure	•	
Water temperature	•	
Oil pressure cooling circuit	•	
Oil level final drives	•	
Float position blade	•	
Fuel level	•	
Contamination hydraulic filter	•	
Contamination air filter	•	
Cold start Diesel engine	•	



Implement hydraulic

	s	o
Hydraulic control 6-way-blade		
Hydraulic control ripper		•
Hydraulic control winch		•
Variable flow pump, load sensing	•	
Oil filter with strainer in hydraulic tank	•	
Blade quick drop	•	
Blade float position	•	
Control block for 4 circuits	•	
Hydraulic tank oil level control	•	
Hydraulic servo control		•



Attachments

	s	o
Mounting plate rear for external tools		
Drawbar rear swivelling		
Drawbar rear rigid		•
Counterweight rear		•
Ripper single shank		•
Ripper 3 shank		•
Rake for landclearing		•
Blade – straight blade		
Blade – semi-U-blade		•
Blade – U-blade		•
Blade – angle blade		•
Blade – woodchip-U-blade		•
Blade – coal-U-blade		•
Blade – landfill blade		•
Push plate		•
Winch		•
Spill plate		•
Wear plates for push arms		•
Wear plates for blades		•

S = Standard Equipment, O = Optional Equipment

Liebherr-Werk Telfs GmbH

Hans-Liebherr-Straße 35, A-6410 Telfs

+43 (0)5262 6 00-0, Fax +43 (0)5262 6 00-72

www.liebherr.com, E-Mail: marketing@lwt.liebherr.com