

# KOMATSU

**PC**  
**160**



PC160LC-7

## PC160LC-7

HYDRAULIC EXCAVATOR

**NET HORSEPOWER**  
82 kW (111 HP)

**OPERATING WEIGHT**  
PC160LC-7: 16.400 - 17.960 kg

**BUCKET CAPACITY**  
0,27 m<sup>3</sup> – 0,95 m<sup>3</sup>

# WALK-AROUND

The PC160LC-7 is a rugged, productive, all-European machine. Designed and expressly built for European markets, it delivers productivity, reliability and operator comforts in a robust, environmentally friendly package. Komatsu's exclusive, on-board, HydraMind system assists in all operations, providing enhanced machine performance that's always perfectly matched to the task.

## What's new on Dash 7:

- Higher production
- Low fuel consumption
- Easier maintenance and serviceability
- Improved operator comfort
- Lower noise
- Meets Eurostage II emission regulations
- Advanced Attachment Control
- Multi-function colour monitor

## Productivity Features

### High productivity and low fuel consumption

Productivity has increased with greater output in the 'Active' mode, while fuel efficiency has been further improved

### Advanced Attachment Control

The PC160LC-7 can be optionally equipped to handle a wide variety of attachments. The advanced attachment control system features:

- Operator selectable hydraulic flow control
- Adjustable pre-sets for rapid attachment changeover
- Attachment piping options

### Larger drawbar pull

Drawbar pull is 15% increased offering superb steering and slope climbing (compared with PC160-6)

### Higher lifting capacity

Lateral stability and lifting capacity have been improved by increasing the track length on ground (compared to PC160-6)

### Easy maintenance

- Extended replacement intervals for engine oil, engine oil filter and hydraulic filter
- Remote-mounted engine oil filter and fuel drain valve, for easy access
- Standard-equipped water separator
- Easier radiator cleaning
- Increased fuel tank capacity
- SCSH bushings on work equipment extend the lubricating interval significantly.
- Increased fuel tank capacity.

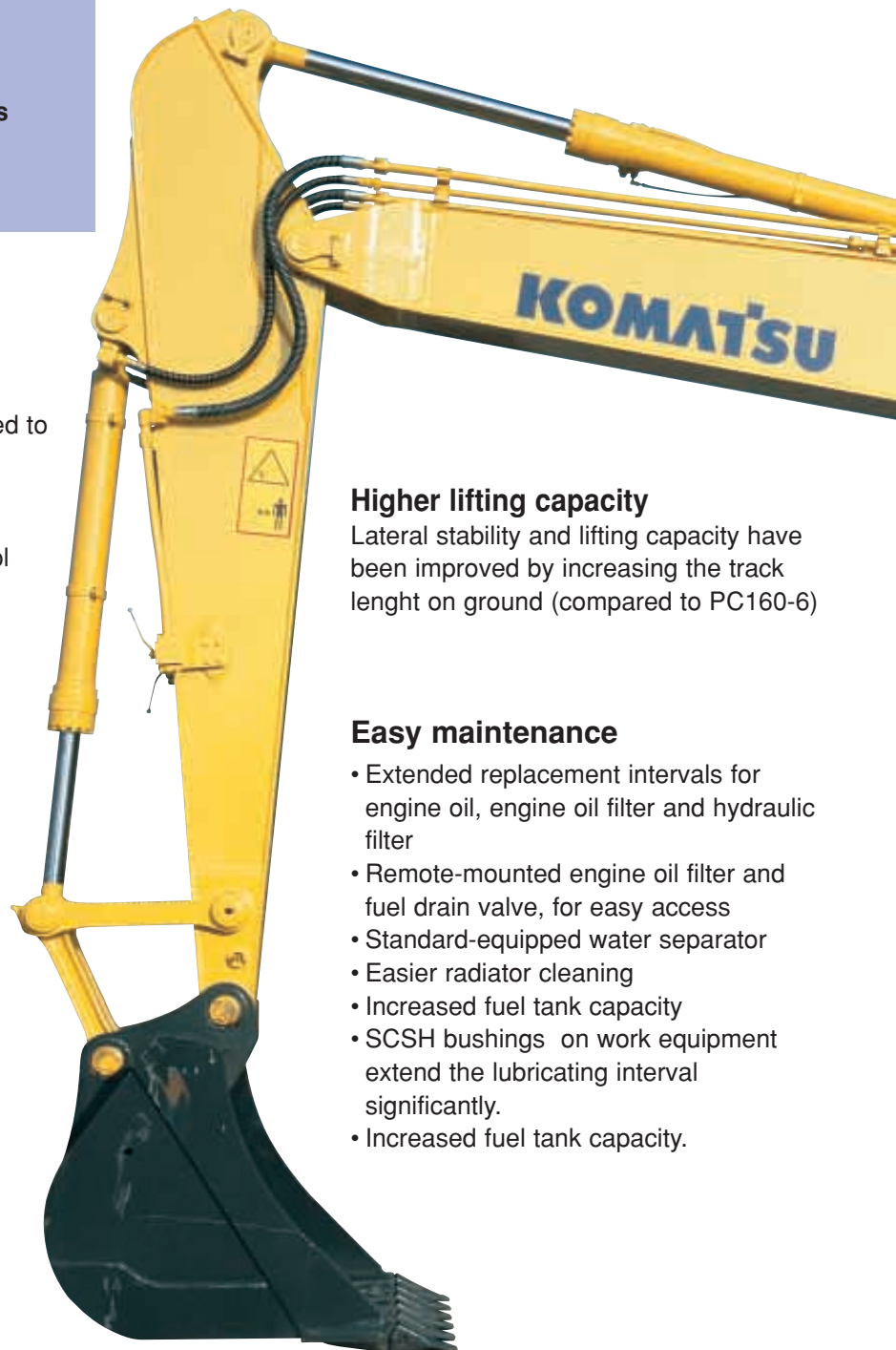

**NET HORSEPOWER**

82 kW (111 HP)

**OPERATING WEIGHT**

PC160LC-7: 16.400 - 17.960 kg

**BUCKET CAPACITY**

0,27 m<sup>3</sup> – 0,95 m<sup>3</sup>

### In harmony with the environment

- Low emission engine  
The powerful turbocharged and air-to-air after cooled Komatsu SAA4D102E-2 provides 82 kW (111 HP). This engine meets Stage II emissions standards with increased power and machine productivity.
- Economy mode reduces fuel consumption
- Low operating noise
- Designed for easy end of life recycling

### SpaceCab™

The new PC160LC-7's cabin space has been increased by 14%, offering an exceptionally roomy operating environment.

- Highly pressurized cabin with standard air conditioner
- Low-noise design
- Low-vibration design with cabin damper mounting
- OPG Level I (ISO) complied cabin

### Excellent reliability and durability

- Reinforced work equipment
- Reliable major components designed and built by Komatsu
- Exceptionally reliable electronic devices
- Strengthened undercarriage that utilises PC210-7 class components.



# EMMS

## EMMS (Equipment Management and Monitoring System)

The EMMS is a highly sophisticated system, controlling and monitoring all the excavator functions. The user interface is highly intuitive and provides the operator with easy access to a huge range of functions and operating information.

### Four working modes

The PC160LC-7 is equipped with three working modes (A, E, B), plus a lifting mode (L). Each mode is designed to match the engine speed, pump speed, and system pressure to the current requirement. This provides the flexibility to match equipment performance to the job at hand.

The diagram shows the EMMS interface on a handheld device. The top section is a color LCD screen displaying various gauges and warnings. Below the screen is a physical keypad with several function buttons. Green callouts (1-14) point to on-screen symbols, and red callouts (1-15) point to physical push-button controls.

### On-screen symbols

- 1 Operating mode
- 2 Service hours meter
- 3 Travel speed
- 4 Engine water gauge
- 5 Engine water temperature warning
- 6 Hydraulic oil gauge
- 7 Hydraulic oil temperature warning
- 8 Fuel level gauge
- 9 Fuel low level warning
- 10 Swing lock
- 11 Pre-heat
- 12 Continuous/intermittent window wiper
- 13 Auto deceleration
- 14 Power max.

### Push-button controls switch

- 1 'Active' mode
- 2 'Economy' mode
- 3 'Lifting' mode
- 4 'Breaker' mode
- 5 Travel speed selector switch
- 6 Auto Deceleration
- 7 Window wiper
- 8 Window washer
- 9 Select (For attachment oil flow adjustment)
- 10 Maintenance mode
- 11 Screen brightness adjustment
- 12 Input (return)
- 13 Input (up)
- 14 Input (down)
- 15 Input (confirm)

### Active Mode

For maximum power and fast cycle times. Normally used for heavy operations such as hard digging and loading. This mode allows access to the 'Power Max' function to temporarily increase digging force by 7% for added power in tough situations.

### Economy mode

The environmentally friendly mode. Run more quietly during operations at night and/or in urban areas. Fuel consumption and CO2 emissions are reduced (compared with the 'Active' mode), and production is equal to the PC160-6's 'HO' mode.

### Breaker mode

Delivers optimal hydraulic pressure, flow and engine RPMs for powerful breaker operations.

### Lifting mode

Increases the lifting capacity 7% by raising the hydraulic pressure. This mode supports safe lifting operations.

Working Mode	Application	Advantage
A	Active mode	<ul style="list-style-type: none"> <li>• Maximum production/power</li> <li>• Fast cycle times</li> </ul>
E	Economy mode	<ul style="list-style-type: none"> <li>• Excellent fuel economy</li> </ul>
B	Breaker mode	<ul style="list-style-type: none"> <li>• Optimum engine rpm and hydraulic flow</li> </ul>
L	Lifting mode	<ul style="list-style-type: none"> <li>• Hydraulic pressure is increased by 7%</li> </ul>

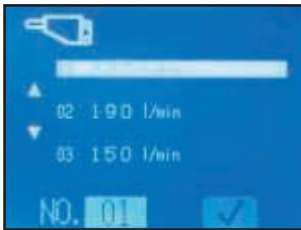

Hydraulic flow general adjustment screen in B (breaker) mode



Fine tune hydraulic flow adjustment screen in B (breaker) mode.



Fine tune hydraulic flow adjustment screen in A (Active) or E (economy) mode.

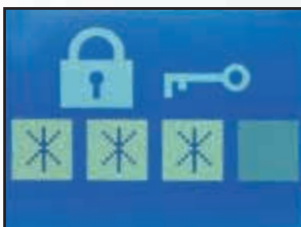

Password screen

### Easy to see and easy to use

Superb recognition colour LCD screens for each mode. Letters and numbers are combined with colour images for exceptionally clear and easy to read information. The high-resolution screen is easy to read in bright sun and in all lighting conditions.

### Password protection

Prevent unauthorized machine transport. The engine cannot be started without your four-digit password. For total security, the battery is connected directly to the starter motor, and it and the engine both need the password. The password can be activated on request.

### Fingertip hydraulic pump oil flow adjustment

From the LCD monitor, automatically select optimal hydraulic pump oil flow for breaking, crushing, and other operations in the B, A or E modes. Also, when simultaneously operating with attachments and work equipment, the flow to the attachment is reduced automatically, thus delivering smooth movement of the work equipment.

### Automatic two-speed travel

Automatic two-speed travel

Travel Speed	High	Low
	5,5 km/h	3,4 km/h

# WORKING ENVIRONMENT

PC160LC-7's cab interior is spacious and provides a comfortable working environment...

## SpaceCab™

### Comfortable cab

The new PC160LC-7 inner cab volume is 14% greater than dash 6, offering an exceptionally comfortable operating environment. The large cab enables the seat back, with headrest, to be reclined horizontal.

### Pressurised cab

The standard-equipped air conditioner, air filter and a higher internal air pressure resist dust entry into the cab.

### Low-noise design

Noise levels are substantially reduced; engine noise as well as swing and hydraulics operations noise.

### Cab damper mounting for low vibration levels

PC160LC-7 uses a new and improved viscous damping cab mount system that incorporates a longer stroke plus an added spring. The new cab damper mounting, combined with strengthened left and right-side decks, aids the reduction of vibrations to the operator's seat.

### Riding comfort comparison

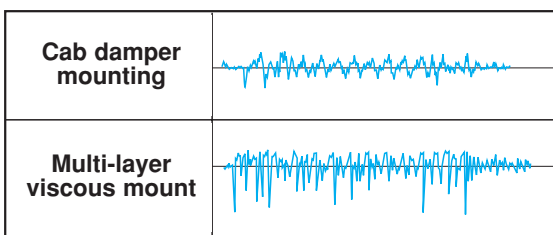

Vertical pitch oscillation on the graph shows the intensity of vibration

**Conditions:**

- Travelling over obstacle one side track
- High-speed forward travel



Easy removal/installation of air conditioner filter element, without tools facilitates easier cleaning.

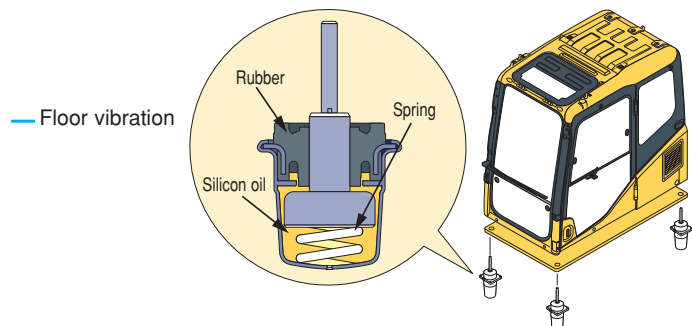

Roof hatch



12-volt power supply and (optional) radio cassette



Climate control



Bottle holder and magazine rack

### Multi-position controls

The multi-position, proportional pressure control levers allow the operator to work in comfort whilst maintaining precise control. A double-slide mechanism allows the seat and controllers to move together, or independently, allowing the operator to position the controllers for maximum productivity and comfort.



Seat sliding range:  
340 mm - increased  
by 120 mm compared  
to dash 6 machines



Defroster / demister.



3 button / functions lever



Hot and cool box

## Safety Features

### Improved, wide visibility

The right side window pillar has been removed and the rear pillar reshaped to provide greater visibility. Blind spots have been decreased by 34%.

### Pump/engine room partition

Prevents hydraulic oil from spraying onto the engine to reduce the risk of fire.

### Thermal and fan guards

Placed around high-temperature parts of the engine. The fan belt and pulleys are well protected.

### Steps with non-slip surface and large handrail

Steps with non-slip surfacing ensure safer maintenance.

Large handrail  
for safe access



Thermal guard



Non slip  
sheet



# PRODUCTIVITY FEATURES

## High production levels and low fuel consumption

The increased output and fuel savings of the Komatsu SAA4D102E-2 engine result in increased production, plus improved production per litre of fuel.



## Engine

The PC160LC-7 gets its exceptional power and work capacity from a Komatsu SAA4D102E-2 engine. Output is 82,4 kW (111 HP), providing increased hydraulic power and improved fuel efficiency.

## Hydraulics

The unique pump system ensures smooth, simultaneous movement of the work equipment. Komatsu's exclusive HydraulMind system controls both of the pumps for most-efficient use of engine power. The system also reduces hydraulic loss during operations. Optional, additional hydraulic circuits may be ordered.



## Greater lifting capacity

PC160LC-7's stability is greater than before. Also the hydraulic pressures are increased. The result: the PC160LC-7's lifting capacity is better. Example: the

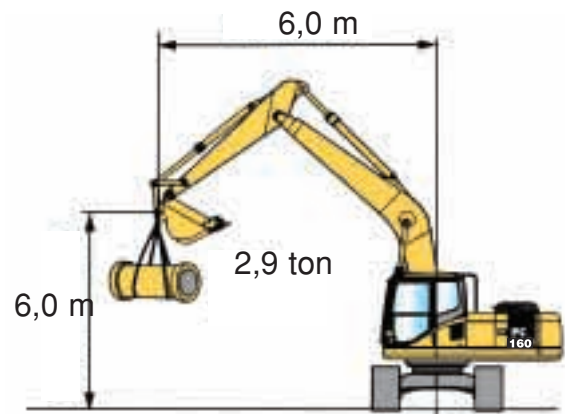

over-side lifting capacity (reach 6,0 m, height 6,0 m) has increased from 2,7 tonnes to 2,9 tonnes. (2,6 m arm)

**Bucket digging force\*:** 12.500 kg  
**Arm crowd force\*:** 9.700 kg

\*Measured with Power Max function, 2,2 m arm and ISO rating

## Larger drawbar pull

PC160LC-7's maximal drawbar pull has been increased by 15% over -6, providing superb steering and slope climbing capacity. Maximum drawbar pull: 15.950 kg

## O.P.G. top and front guard.

The optional bolt-on OPG (Operation Protection Guard) topguard and front guard are available for operations in jobsites where there is high possibility of falling rocks or debris. OPG level 2 for top and front guard according to iso10262



## Excellent reliability and durability

### Reliable components

All of the major machine components, such as engine, hydraulic pump, hydraulic motor and control valves, are exclusively designed and manufactured by Komatsu. This guarantees that each component is expressly built for the class and model of machine. This ensures that the engineering, manufacturing standards and testing that go into each component are 'totally-Komatsu'.

### Highly-rigid, robust work equipment

The strengthened boom and arm have large cross-sectional dimensions as well as continuous two-sided groove welding, improving the digging and side-contact strengths.

### Sturdy frame structure

The revolving frame, centre frame and undercarriage have been designed using the most advanced three-dimensional computer aided design (CAD) and FEM (Finite Elements Modelling) analysis technology.

### Highly-reliable electronic devices

Exclusively-designed electronic devices are certified by severe testing.

- Controller
- Sensors
- Connectors
- Heat-resistant wiring

### Metal guard rings

Protect all hydraulic cylinders and improve reliability.

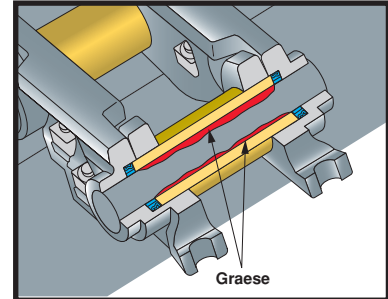

Grease-sealed track provides excellent undercarriage durability



Track Link with Strut  
The PC160LC-7 uses track links with strut, providing superb durability.

## Harmony with the environment

### Low-emission engine

Komatsu SAA4D102E-2 is EC stage II compliant, with reduced NOx emissions, compared to the PC160-6.

### Low noise

Noise is reduced from the engine as well as from swing and hydraulic operations. The dynamic noise level is just 69LpA and 102LwA.

### Economy (environment) mode

'Economy' mode meets the needs of the 21st century. This mode offers the user fuel savings, quiet operation, and less CO2 emissions.

- Fuel consumption is reduced (compared to the dash 6 'Active' mode).
- Production is the same as the PC160-6's 'HO mode'.

### Easily end of life recycled

PC160LC-7 is designed with consideration of end of life recycling, effectively reducing its environmental impact.

- All exterior parts are made of steel.
- Extended engine oil, hydraulic oil and filter replacement intervals reduce environmental impact.
- All plastic parts are given a material code symbol.

# VHMS

## VHMS (Vehicle Health Monitoring System)

VHMS's precise health-check system indicates all of the machine's running conditions. At the beginning of, and during, each work shift, abnormality information and machine functions can be checked from the operator's seat.

### New features: VHMS Machine health monitoring

- Failures are indicated with a 6-digit failure code
- Up to four different mechanical system measurements can be monitored at the same time
- A "Maintenance Indicator" function has been added. (Filter and oil replacement time display function)
- Mechanical system failures are now monitored, in addition to electrical system failures.

### Displays running conditions and abnormality indications

At the operator's fingertips: the VHMS controller monitors engine oil level, cooling water level, fuel level, engine water temperature, engine oil pressure, battery charging level, air filter clogging, and more. The monitor also indicates whenever abnormalities are detected.

### Maintenance alert assistance

The VHMS monitor alerts that oil and filters need to be replaced when the replacement interval is reached.

### Operation data memory

The system memorises machine operating data such as engine output, hydraulic pressure, and more.

### Trouble data memory

The monitor stores and recalls electrical system and mechanical system failures and abnormalities for effective troubleshooting. Twenty most-recent electrical system failures are stored. Mechanical system failures cannot be erased, ensuring accurate documentation of vital service management information.

### VHMS 'real time monitoring system'

The 'real time monitoring system' displays up to four different operating parameters simultaneously, giving the mechanic a total overview for faster troubleshooting. Parameters include operating conditions such as hydraulic oil pressure, engine RPMs, different voltages current, and even temperature measurement.

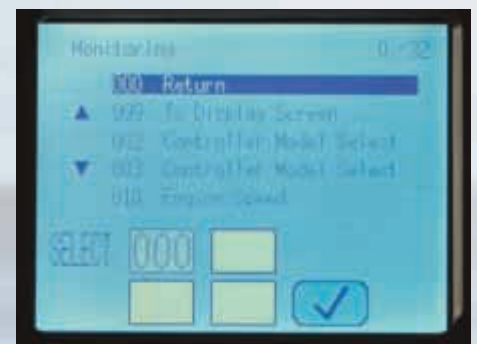

Real time monitoring

## Reducing maintenance costs

### Extended replacement intervals for engine oil and filters.

New, high-performance filters are used in the hydraulic circuit and engine. Replacement intervals for the hydraulic oil filter are significantly extended, reducing maintenance costs.

Replacement intervals table: unit: hours

	PC160LC-7
Engine oil	500
Engine oil filter	500
Hydraulic oil filter	1.000
Hydraulic oil	5.000



### Fuel tank capacity increased

The fuel tank capacity has increased from 250 litres to 280 litres to extend the operating hours between refuelling. The fuel tank is treated for rust prevention and improved corrosion resistance.

### With SCSH bushings, all work equipment lubrication intervals are extended

Newly-developed SCSH (Steel Copper Sinter Hard Material) bushings are used on all work equipment joints\*. As a result, all work equipment bushing lubrication intervals are significantly extended, with some joints only needing lubrication every 500 hours, thus reducing maintenance costs.

\*Available for bucket pin, depending on bucket design

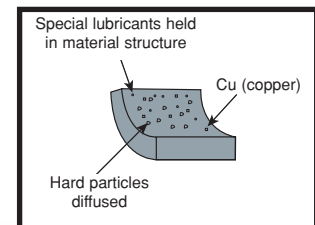

SCSH bushing

### Tungsten carbide-injected bushing

Tungsten carbide is injected into the end faces of the arm-top bushing to form a hard film. This reduces the wear of contacting surfaces and fluttering of the bucket

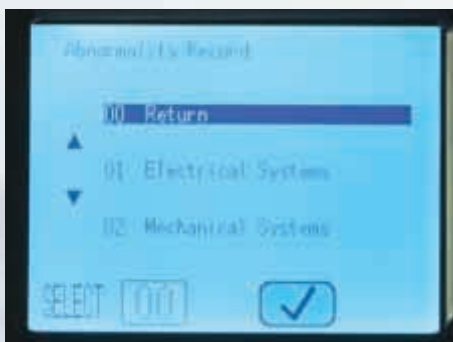

Trouble Data memory



Maintenance record



Maintenance mode change

# MAINTENANCE FEATURES

## Easy maintenance

Komatsu designed the PC160LC-7 to have easy service access. By doing this, routine maintenance and servicing are less likely to be skipped. This can mean a reduction in costly downtime later on. Here are some of the many service features found on the PC160LC-7.

### Side-by-side cooling

Since radiator, aftercooler and oil cooler are arranged in parallel, it is easy to clean, remove and install them.



### Water separator

Standard equipment which removes any water that has become mixed with the fuel, preventing fuel system damage.



### Easy access to engine oil filter and fuel drain valve

Engine oil filter and fuel drain valve are remotely mounted to improve accessibility.



# SPECIFICATIONS



## ENGINE

Type ..... 4 cylinder, direct injection, emissionised, turbocharged, after-cooled diesel.  
 Model ..... Komatsu SAA4D102E-2  
 Power rating  
 ISO 9249 (Net) ..... 82 kW (111 HP) at 2.200 rpm  
 Bore x stroke ..... 102 mm x 120 mm  
 Piston displacement ..... 3,92 litre  
 Air-cleaner and cooling ..... Double element type with monitor panel dust indicator and auto dust evacuator.  
 Suction type cooling fan with radiator fly screen.



## ELECTRICAL SYSTEM

Alternator ..... 24 Volt – 60 ampere  
 Batteries ..... 2 x 12 Volt – 95 Ah  
 Starter motor ..... 24 Volt – 4,5 kW



## HYDRAULIC SYSTEMS

Type ..... HydrauMind. Closed-centre system with load sensing and pressure compensation valves.  
 Additional circuits ..... Depending on specification up to 1 additional circuit can be installed.  
 Main pump ..... variable displacement piston pump supplying boom, arm, bucket, swing and travel circuits.  
 Maximum pump flow ..... 312 ltr/min  
 Relief valve settings  
 Implement ..... 380 kg/cm<sup>2</sup>  
 Travel ..... 380 kg/cm<sup>2</sup>  
 Swing ..... 295 kg/cm<sup>2</sup>  
 Pilot circuit ..... 33 kg/cm<sup>2</sup>



## ENVIRONMENT

Engine emissions ..... Fully complies with stage 2 exhaust emission regulations.  
 Noise levels ..... LWA External noise 102 dB(A) (2000/14/EC)  
 LPA Operator ear noise 69 dB(A) (iso6396)



## OPERATION WEIGHT

Operating weight, including 5150 mm one-piece boom, two-piece boom, 2,6 m arm, 0,65m<sup>3</sup> bucket, operator, lubricant, coolant, full fuel tank and the standard equipment.



## SWING SYSTEM

Type ..... hydrostatic  
 Swing lock ..... mechanical disc brake  
 Swing speed ..... 12 rpm.



## DRIVES & BRAKES

Steering control ..... 2 levers with pedals giving full independent control of each track.  
 Drive method ..... Hydrostatic.  
 Travel operation ..... Automatic 2-speed selection  
 Gradeability ..... 70%, 35°  
 Travel speeds Lo / Hi ..... 3,4 / 5,5 km/h  
 Maximum drawbar pull ..... 15.950 kg  
 Brake system ..... Mechanical disc brake (parking)  
 Hydraulic lock (service)



## UNDERCARRIAGE

Construction ..... X-frame centre section with box section track-frames  
 Track assembly  
 Type ..... Fully sealed.  
 Shoes (each side) ..... 44  
 Tension ..... Combined spring and hydraulic unit  
 Rollers  
 Track rollers (each side) ..... 7  
 Carrier rollers (each side) ..... 2



## SERVICE / REFILL CAPACITIES

Fuel tank ..... 280 ltr  
 Radiator ..... 17,3 ltr  
 Engine ..... 14,0 ltr  
 Swing drive ..... 4,5 ltr  
 Hydraulic tank ..... 121 ltr  
 Final drive (each side) ..... 4,5 ltr

MONO BOOM			TWO PIECE BOOM	
Triple grouser shoe	PC160LC-7			
	Operating weight	Ground pressure	Operating weight	Ground pressure
500 mm	16.400 kg	0,47 kg/cm <sup>2</sup>	17.300 kg	0,50 kg/cm <sup>2</sup>
600 mm	16.620 kg	0,40 kg/cm <sup>2</sup>	17.520 kg	0,43 kg/cm <sup>2</sup>
700 mm	16.840 kg	0,35 kg/cm <sup>2</sup>	17.740 kg	0,37 kg/cm <sup>2</sup>
800 mm	17.060 kg	0,31 kg/cm <sup>2</sup>	17.960 kg	0,33 kg/cm <sup>2</sup>

# MACHINE DIMENSIONS

MACHINE DIMENSIONS	PC160LC
A Overall width of upper structure	2.490 mm
B Overall height of cab	2.970 mm
C Overall length of basic machine	4.373 mm
D Tail length	2.390 mm
Tail swing radius	2.435 mm
E Clearance under counterweight	1.055 mm
F Machine tail height	2.090 mm
G Ground clearance	440 mm
H Track length on ground	3.170 mm
I Track length	3.965 mm
J Track gauge	1.990 mm
K Track shoe width	500, 600, 700, 800 mm
L Overall track width with 500 mm shoe	2.490 mm
600 mm shoe	2.590 mm
700 mm shoe	2.690 mm
800 mm shoe	2.790 mm

## MONO BOOM

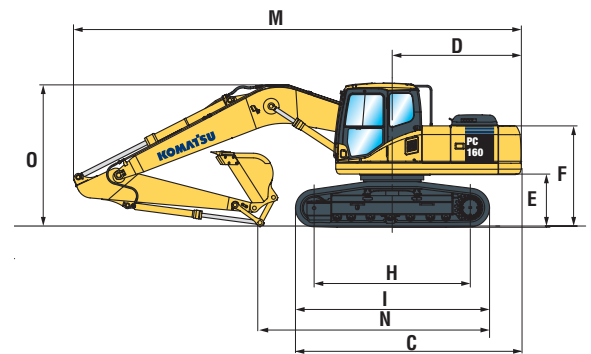
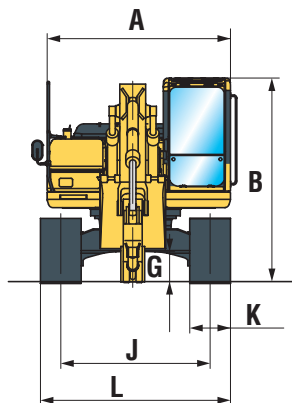

## TWO PIECE BOOM

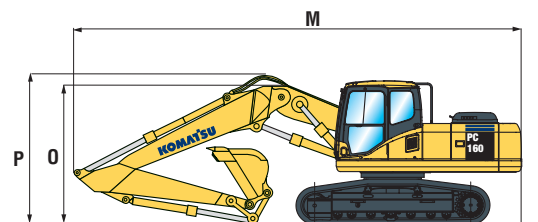

Arm length	Mono boom			Two piece boom		
	2,2 m	2,6 m	2,9 m	2,2 m	2,6 m	2,9 m
M Transport length	8.565 mm	8.565 mm	8.565 mm	8.550 mm	8.550 mm	8.525 mm
N Length on ground (transport)	5.130 mm	4.760 mm	4.565 mm	5.400 mm	5.100 mm	4.900 mm
O Overall height (to top of boom)	2.990 mm	3.000 mm	3.100 mm	-	-	-
P Overall height (to top of hose)	-	-	-	3.105 mm	3.170 mm	3.280 mm



### BUCKET OPTIONS & DIGGING FORCES

Specifications and equipments may vary according to regional availability

## PC160LC-7

Width mm	Capacity m <sup>3</sup> SAE	Weight	PC160LC-7 arm length		
			2,2 m	2,6 m	2,9 m
450	0,27 m <sup>3</sup>	369 kg	○	○	○
600	0,40 m <sup>3</sup>	413 kg	○	○	○
700	0,49 m <sup>3</sup>	451 kg	○	○	○
800	0,58 m <sup>3</sup>	480 kg	○	○	○
900	0,67 m <sup>3</sup>	518 kg	○	○	○
1000	0,76 m <sup>3</sup>	547 kg	□	□	□
1200	0,95 m <sup>3</sup>	614 kg	△	△	-

- Material weight up to 1,8 t/m<sup>3</sup>
- Material weight up to 1,5 t/m<sup>3</sup>
- △ Material weight up to 1,2 t/m<sup>3</sup>
- Not recommended.

Please consult with your distributor for the correct selection of buckets and attachments to suit the application.

The recommendations are given as a guide only, based on typical operating conditions.

A full range of Komatsu wear parts is available.



**ABRASION**



**SHARP**



**GENERAL PURPOSE**



**PENETRATION**

BUCKET AND ARM FORCE			
Arm length	2,2 m	2,6 m	2,9 m
Bucket digging force	11.500 kg	11.500 kg	11.500 kg
Bucket digging force at power max.	12.500 kg	12.500 kg	12.500 kg
Arm crowd force	9.050 kg	8.200 kg	7.550 kg
Arm crowd force at power max.	9.700 kg	8.800 kg	8.100 kg

# WORKING RANGES

## MONO BOOM

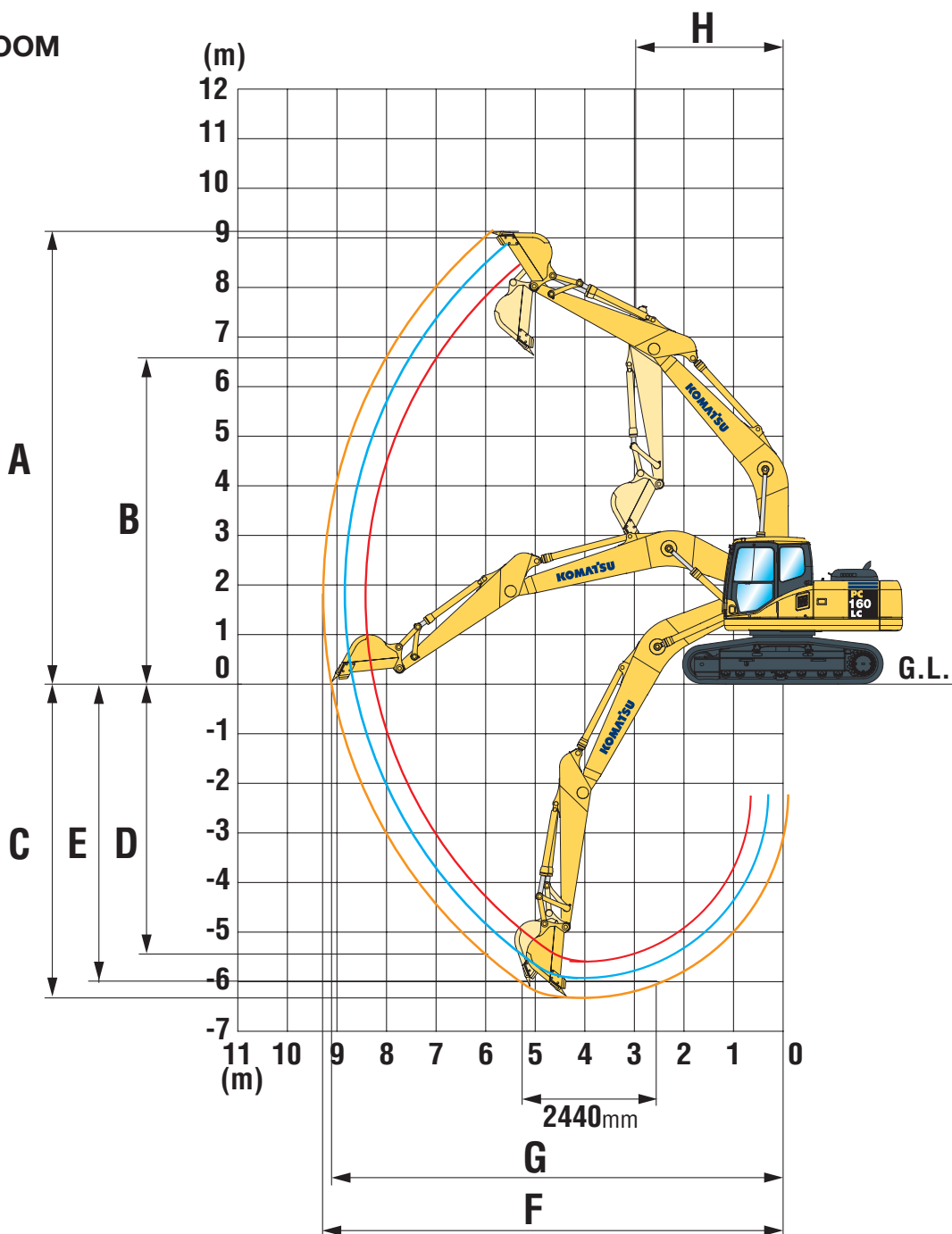

Arm length	2,2 m	2,6 m	2,9 m
A Max. digging height	8.910 mm	8.980 mm	9.130mm
B Max. dumping height	6.280 mm	6.370 mm	6.525 mm
C Max. digging depth	5.610 mm	5.960 mm	6.250 mm
D Max. vertical wall digging depth	4.860 mm	5.040 mm	5.320 mm
E Max. digging depth of cut for 2,44 m level	5.375 mm	5.740 mm	6.050 mm
F Max. digging reach	8.680 mm	8.960 mm	9.235 mm
G Max. digging reach at ground level	8.510 mm	8.800 mm	9.075 mm
H Min. swing radius	3.040 mm	2.990 mm	2.995 mm

## TWO PIECE BOOM

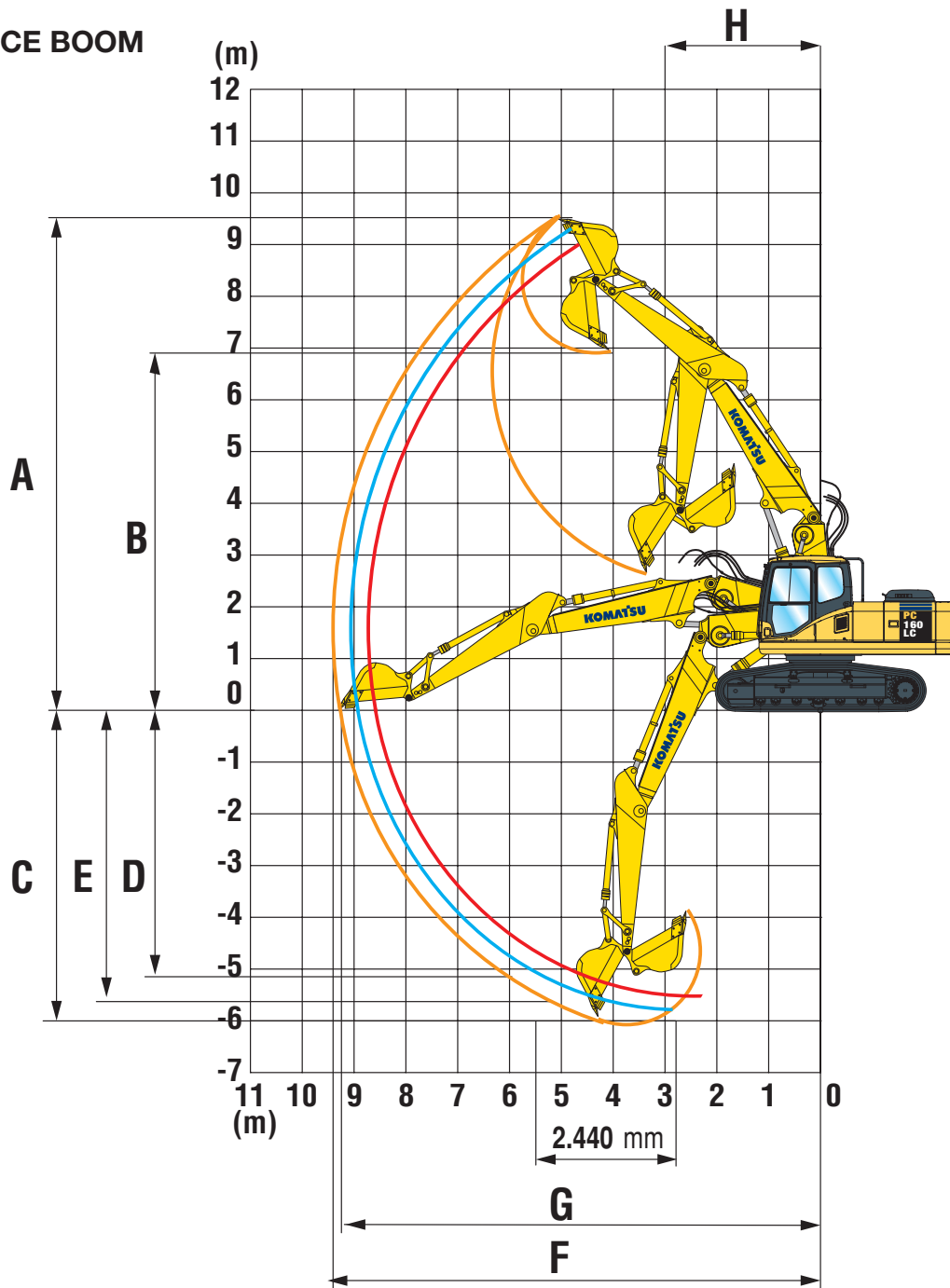

Arm length	2,2 m	2,6 m	2,9 m
A Max. digging height	9.245 mm	9.375 mm	9.555 mm
B Max. dumping height	6.575 mm	6.715 mm	6.900 mm
C Max. digging depth	5.440 mm	5.780 mm	6.070 mm
D Max. vertical wall digging depth	4.525 mm	4.810 mm	5.085 mm
E Max. digging depth of cut for 2,44 m level	5.331 mm	5.676 mm	5.970 mm
F Max. digging reach	8.755 mm	9.060 mm	9.335 mm
G Max. digging reach at ground level	8.590 mm	8.900 mm	9.180 mm
H Min. swing radius	3.030 mm	2.960 mm	3.000 mm

# LIFTING CAPACITY

## PC160LC-7 ONE-PIECE BOOM

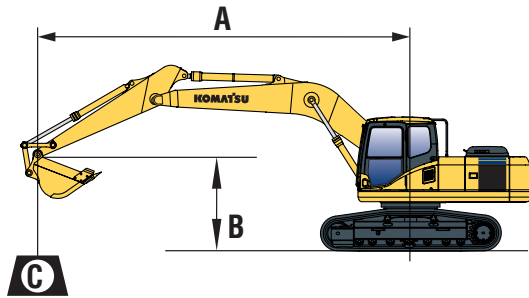



A – Reach from swing center













B – Bucket hook height



C – Lifting capacities, including bucket linkage (200 kg) and bucket cylinder (140 kg)



When removing bucket, linkage or cylinder, lifting capacities can be increased by their respective weights

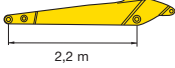

With 500 mm shoe

-  – Rating over front
-  – Rating over side
-  – Rating at maximum reach

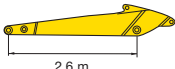
Arm length	A			7,5 m		6,0 m		4,5 m		3,0 m		1,5 m	
													

With 500 mm shoe  2,2 m  495 kg 0,65 m <sup>3</sup>	6,0m	* 2.400	* 2.400			* 3.250	2.850						
		4,5m	* 2.350	2.050			* 4.450	2.850	* 5.000	4.650			
	3,0m	* 2.450	1.800			4.450	2.700	* 6.300	4.300	* 9.700	8.150		
	1,5m	* 2.700	1.700	2.950	1.750	4.300	2.550	6.700	3.850				
	0,0m	2.950	1.700			4.150	2.400	6.550	3.750	* 6.750	* 6.750		
	-1,5m	3.300	1.950			4.100	2.400	6.500	3.650	* 10.600	6.950	* 6.200	* 6.200
	-3,0m	4.200	2.450					6.550	3.700	* 10.500	7.100	* 10.250	* 10.250
	-4,5m	* 4.850	4.200							* 7.050	* 7.050		

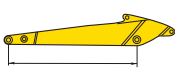
With 500 mm shoe  2,6 m  495 kg 0,65 m <sup>3</sup>	6,0m	* 2.000	* 2.000			* 3.350	2.900						
		4,5m	* 2.000	1.900			* 4.200	2.850					
	3,0m	* 2.050	1.650	3.050	1.800	4.500	2.750	* 5.900	4.400	* 8.700	8.450		
	1,5m	* 2.300	1.600	3.000	1.750	4.300	2.550	6.900	4.000	* 7.850	7.350		
	0,0m	* 2.650	1.600	2.900	1.700	4.150	2.450	6.600	3.750	* 7.350	6.950		
	-1,5m	3.050	1.750			4.100	2.350	6.500	3.650	* 10.150	6.950	* 5.800	* 5.800
	-3,0m	3.800	2.200			4.100	2.400	6.500	3.650	* 11.150	7.050	* 9.200	* 9.200
	-4,5m	* 4.950	3.450					* 5.550	3.850	8.200	7.350		

With 500 mm shoe  2,9 m  495 kg 0,65 m <sup>3</sup>	6,0m	* 1.750	* 1.750			* 3.250	2.950						
		4,5m	* 1.700	* 1.700	* 2.250	1.850	* 3.900	2.850					
	3,0m	1.800	1.550	3.050	1.800	4.500	2.700	* 5.500	4.400	* 7.850	* 7.850		
	1,5m	* 1.950	1.450	2.950	1.700	4.300	2.550	6.900	4.000	* 10.000	7.450		
	0,0m	* 2.250	1.450	2.850	1.650	4.100	2.400	6.600	3.700	* 7.650	6.950		
	-1,5m	* 2.800	1.600	2.850	1.600	4.050	2.300	6.400	3.600	* 9.750	6.800	* 5.400	* 5.400
	-3,0m	3.450	1.950			4.050	2.300	6.400	3.600	* 11.500	6.900	* 8.400	* 8.400
	-4,5m	* 4.800	2.950					* 6.050	3.700	* 8.900	7.200		

\* Load is limited by hydraulic capacity rather than tipping.  
 Ratings are based on SAE Standard No. J1097.  
 Rated loads do not exceed 87% of hydraulic lift capacity or 75% of tipping load.

### PC160LC-7 TWO-PIECE BOOM

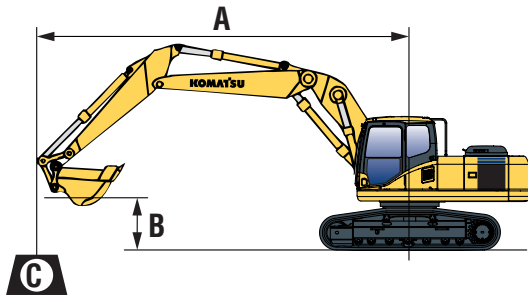

- A – Reach from swing center
- B – Bucket hook height
- C – Lifting capacities, including bucket linkage (200 kg) and bucket cylinder (140 kg)

When removing bucket, linkage or cylinder, lifting capacities can be increased by their respective weights

With 500 mm shoe

- Rating over front
- Rating over side
- Rating at maximum reach

Arm length	A			7,5 m		6,0 m		4,5 m		3,0 m		1,5 m	

With 500 mm shoe	7,5m	* 2.900	* 2.900			* 3.750	2.900			* 5.250	4.650		
	6,0m	* 2.500	* 2.500			* 3.750	2.900			* 5.250	4.650		
	4,5m	* 2.400	2.000			4.650	2.850	* 6.200	4.350	* 9.400	8.200		
	3,0m	* 2.450	1.750	3.050	1.800	4.500	2.700	* 6.200	4.350	* 9.400	8.200		
	1,5m	* 2.650	1.650	3.000	1.750	4.300	2.550	6.750	3.850				
	0,0m	2.950	1.700	2.950	1.700	4.200	2.450	6.600	3.750	* 5.750	* 5.750		
	-1,5m	3.250	1.900			4.150	2.400	6.550	3.650	* 9.750	7.000		
	-3,0m	* 4.100	2.400			4.200	2.450	6.600	3.750				

With 500 mm shoe	7,5m	* 2.350	* 2.350			* 3.650	2.950						
	6,0m	* 2.100	* 2.100			* 3.650	2.950						
	4,5m	* 2.000	1.850	* 2.050	1.850	* 4.200	2.900						
	3,0m	* 2.050	1.600	3.050	1.800	4.550	2.750	* 5.750	4.400	* 8.250	* 8.250		
	1,5m	* 2.250	1.550	3.000	1.750	4.350	2.550	6.950	4.000	* 6.600	* 6.600		
	0,0m	* 2.550	1.550	2.950	1.700	4.200	2.450	6.650	3.750	* 6.400	* 6.400		
	-1,5m	3.000	1.750			4.100	2.350	6.550	3.650	* 9.400	6.950		
	-3,0m	3.700	2.150			4.150	2.400	6.550	3.700	* 14.250	7.100		

With 500 mm shoe	7,5m	* 2.050	* 2.050			* 3.450	2.950						
	6,0m	* 1.800	* 1.800			* 3.450	2.950						
	4,5m	* 1.750	1.700	* 2.650	1.850	* 2.850	2.900						
	3,0m	* 1.800	1.500	3.050	1.800	4.550	2.750	* 5.400	4.450	* 7.300	* 7.300		
	1,5m	* 1.900	1.400	3.000	1.700	4.350	2.550	7.000	4.050	* 8.550	7.500		
	0,0m	* 2.150	1.450	2.900	1.650	4.150	2.400	6.650	3.750	* 6.700	* 6.700		
	-1,5m	* 2.650	1.550	2.850	1.600	4.050	2.300	6.450	3.600	* 9.000	6.850	* 4.750	* 4.750
	-3,0m	3.350	1.900			4.050	2.300	6.500	3.600	* 13.350	6.950		

\* Load is limited by hydraulic capacity rather than tipping.  
 Ratings are based on SAE Standard No. J1097.  
 Rated loads do not exceed 87% of hydraulic lift capacity or 75% of tipping load.

# CRAWLER EXCAVATOR



## STANDARD EQUIPMENT

Standard and optional equipment may vary. Consult your Komatsu dealer for more information.

- Komatsu SAA4D102E-2 82kW direct injection
- Track roller guards
- Emissionised EC stage II intercooled turbo charged diesel
- Parts book and operator manual
- Lockable fuel cap and covers.
- Double element type air-cleaner with dust indicator and auto-dust evacuator.
- Remote greasing for swing circle and pins.
- Fuel supply pump
- Suction type cooling fan with radiator fly screen.
- Track frame under-guards
- Automatic fuel line de-aeration
- 12 Volt power supply
- Engine key stop
- Overload warning device
- 500 mm shoe
- Alternator, 24 Volt 60 A
- Boom safety valves
- Batteries, 2x12 Volt 95Ah
- Large handrails and rear-view mirrors
- Starter motor, 24 Volt 4,5 kW
- Cigarette lighter
- Electronic closed-centre load sensing
- Radio cassette preparation.
- (E-CLSS) hydraulic system (HydrauMind).
- Beverage holder and magazine rack
- Pump and engine mutual control (PEMC) system
- Electrical horn
- Multi function colour monitor with equipment management monitoring system (EMMS)
- Climate control / Airconditioning
- 4-working mode selection system;
- Hot and cool box.
- Active mode, economy mode, breaker mode and lifting mode
- Toolkit and spare parts for first service.
- Lights; 2 revolving frame lights and 1 boom light
- Standard colour scheme and decals
- Power-Max function
- Suspension seat with adjustable arm rests and retractable seat belt.
- Auto-deceleration function.
- Engine ignition can be password secured on request.
- Automatic engine warm-up system.
- Engine overheat prevention system.
- Fuel control dial.
- Adjustable PPC wrist control levers with 3 button controls for arm, boom, bucket and swing.
- PPC control levers and pedals for steering and travel.
- One additional service valve ( full flow )
- Hydrostatic, 2-speed travel system with auto shift and planetary gear type final drives, and hydraulic travel and parking brakes.
- SpaceCab™ ; Highly pressurized and tightly sealed viscous mounted cab with tinted safety glass windows, opening roof hatch with window pull-up type front window with locking device, removable lower window, front window wiper with intermittent feature, ashtray, luggage box, floor mat

## OPTIONAL EQUIPMENT

- Heated air suspension seat
- 600, 700, 800, mm triple grouser track-shoes
- Mono boom
- Two piece boom
- Customized paint
- 2,2 m, 2,6 m, 2,9 m arms
- Automatic greasing system
- Additional hydraulic circuits
- Arm safety valve
- KOMATSU buckets
- Rain visor ( not for use with OPG)
- Radio-Cassette
- Service points
- Beacon preparation
- Bio oil
- OPG top guard
- OPG front guard



**Komatsu Europe International NV**  
 Mechelsesteenweg 586  
 B-1800 VILVOORDE (BELGIUM)  
 Tel. +32-2-255 24 11  
 Fax +32-2-252 19 81  
 www: komatsueurope.com