

KOMATSU

D
41



D41E/P-6

D41E/P-6

CRAWLER DOZER

FLYWHEEL HORSEPOWER
82 KW (110 HP)
@ 2,300 rpm

OPERATING WEIGHT
D41E-6: 11.380 kg
D41P-6: 11.880 kg

WALK-AROUND

Palm command joysticks

Left hand joystick controls all tractor motion.
Right hand joystick controls all blade movements.

The Komatsu SA6D102E-2A turbocharged and aftercooled diesel engine

provides an output of 82 kW (110 HP), with excellent productivity, while meeting European Stage II and EPA TIER II emissions regulations.

Hydrostatic driven engine cooling fan

controlled automatically, reduces fuel consumption and operating noise levels.

Gull-wing engine side doors

for easier and safer servicing.

High capacity power angle tilt dozer

combines the highest power with outstanding productivity.

Super-angle blade

facilitates transportation of D41-6.

Blade tilt lines

completely protected.

Komatsu hydroshift transmission

offers single lever control of speed (3 forward and 3 reverse) and directional changes.

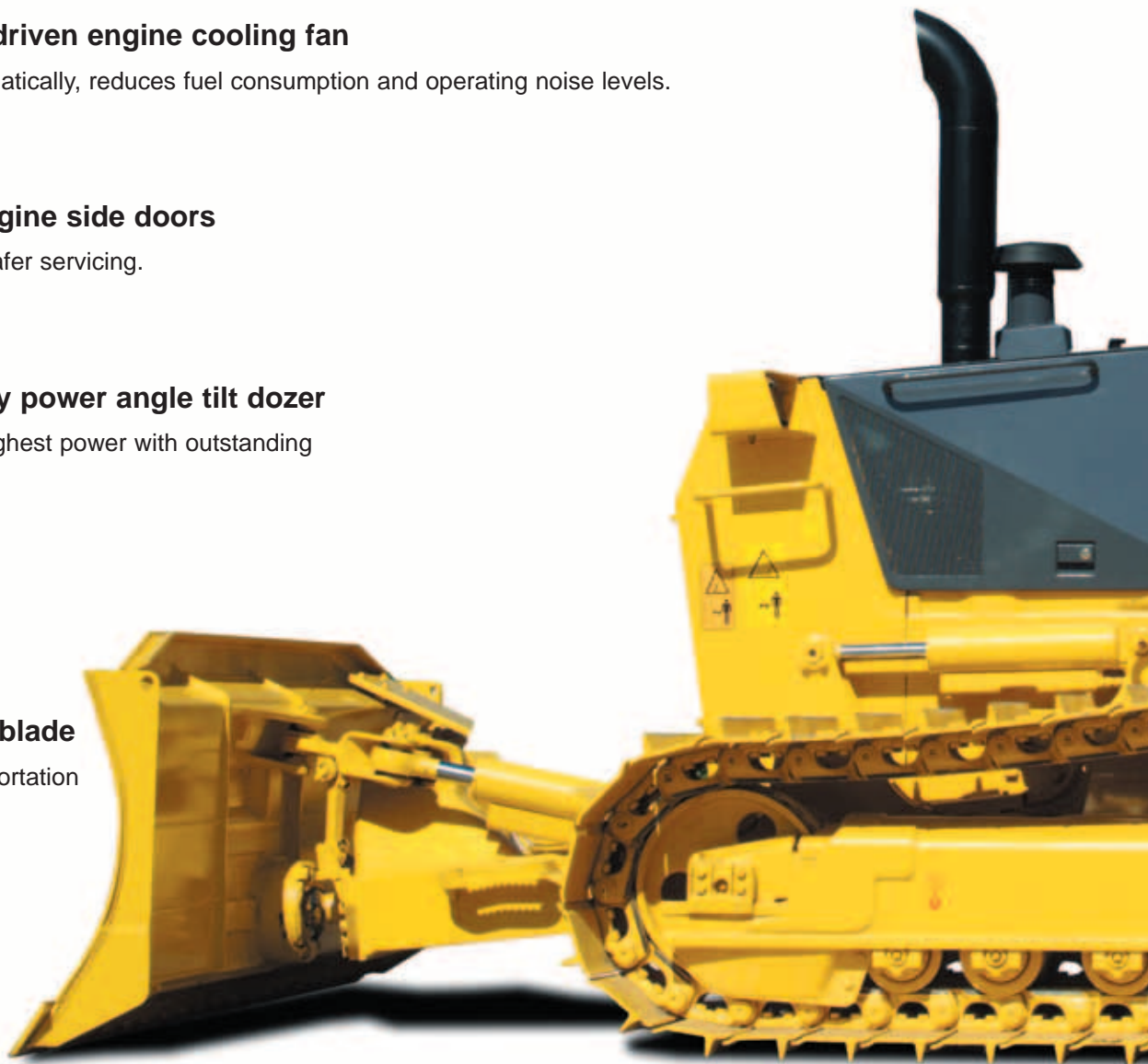

D41E/P-6 CRAWLER DOZER

FLYWHEEL HORSEPOWER

82 kW (110 HP)
@ 2.300 rpm

OPERATING WEIGHT

D41E-6: 11.380 kg
D41P-6: 11.880 kg

BLADE CAPACITY

PAT Dozer:
D41E/P-6: up to 2,9 m³

New hexagonal designed SpaceCab™ includes

- Spacious interior
- Comfortable ride with new cab damper
- Excellent visibility
- High capacity air conditioning system
- Pressurised cab
- Adjustable armrests
- State-of-the-art highback seat
- Heated rear window
- Pre radio installation kit
- 12 V connector
- viscous damping mounts



Electronic monitoring system

prevents minor problems from developing into major ones.

Wet, single-disc brakes

eliminates brake-disc adjustments for maintenance-free operation.

Active steering system

The active steering system allows the dozer to make smooth turns while still keeping power transmission on both tracks.

Modular power train

for increased serviceability and durability.

WORK ENVIRONMENT

Operator comfort

Operator comfort is essential for safe and productive work. The D41E/P-6 provides a quiet, comfortable environment where the operator can concentrate on the work at hand.

Hexagonal pressurised SpaceCab™

- The cab's new hexagonal design and large tinted glass windows provide excellent front, side, and rear visibility.
- The new sealing system on doors and windows combined with large air filters and a higher internal air pressure prevents dust from entering the Space Cab™.

Comfortable ride with new cab damper mounting

D41E/P-6 Space Cab™ uses a newly designed cab damper that provides an excellent shock and vibration absorption capacity with its long stroke. The viscous mount cab damper greatly reduces shocks and vibrations while dozing and ripping. As a result, both the vibrations and noise level in the operator compartment are reduced to the minimum.

Cab damper mounting

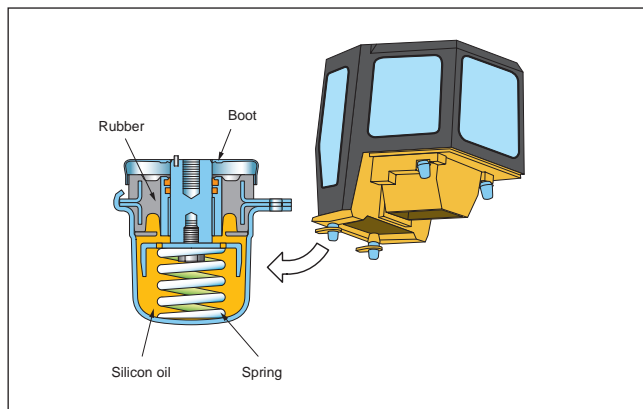

New suspension seat

D41E/P-6 uses a newly designed heavy-duty suspension seat. Fore and aft sliding rails and suspension spring have been newly designed to increase durability and rigidity. The new seat provides excellent support, improving riding comfort.

Ergonomical joystick

All steering, direction, and speed changes are made by a left-hand single joystick control. If the operator wants to move the machine forward and to the left, he simply moves the joystick forward and to the left. Gear changes can be done by twisting the steering lever. The machine responds to the movement of the lever, providing the operator a feeling of natural control with Komatsu's joystick.

Easy-to-operate work equipment control lever

With the Closed-center Load Sensing hydraulic System (CLSS), blade lever stroke is directly proportional with blade speed, regardless of the load and travel speed. This results in superb, fine controllability.

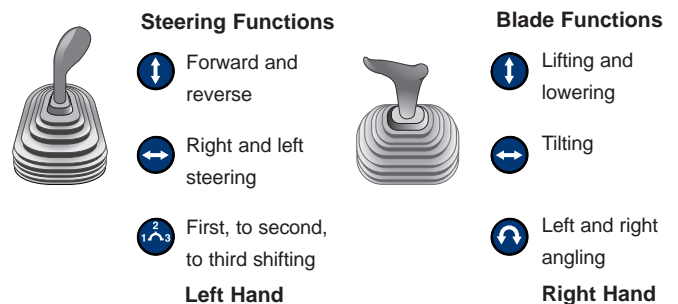

Benefits of CLSS

- More precise and responsive operation due to the pressure compensation valve.
- Reduced fuel consumption by discharging only the required amount of oil from the work equipment pump.
- Compound operation such as blade raise, tilt and angle is easy due to CLSS parallel circuit with pressure compensation valve.

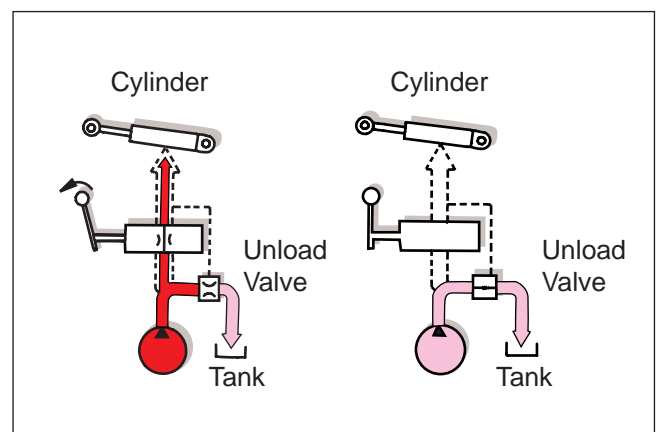

PRODUCTIVITY FEATURES

Komatsu SA6D102E-2A - Turbocharged Aftercooled Diesel Engine

Powerful engine

A powerful SA6D102E-2A turbocharged aftercooled diesel engine provides a rated output of 82 kW (110 HP). The engine power is transmitted smoothly to the final drives via a high-efficiency Hydroshift transmission. This engine meets European stage II and American EPA Tier II emissions regulations, without sacrificing power or machine productivity.

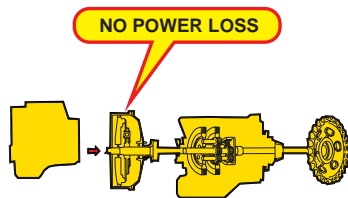

Hydroshift transmission

The D41-6 is equipped with Komatsu's unique hydroshift transmission, assuring smooth gear shifts, powerful traction and low fuel consumption. It consists of a damper and planetary gear transmission. The engine power is efficiently converted into traction by the hydroshift transmission and this by using direct drive transmission. The combination: damper with hydroshift transmission, gives the highest power transmission efficiency in his class.

Hydrostatic driven cooling fan

Fan rotation is automatically controlled depending on coolant and hydraulic oil temperature, saving fuel consumption and providing great productivity with a quiet operating environment.

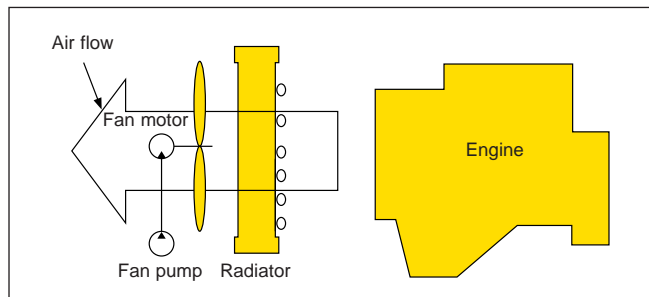

Easy cleaning radiator core

The radiator core and the core on the front side of the oil cooler can be easily cleaned by running the hydrostatic driven cooling fan in reverse. This will result in better cooling efficiency and higher engine performance.



VERSATILITY

Super angle blade Blade angles responding to job-site conditions

Easy transportation

Komatsu's super-angle blade, angles freely to a maximum of 55°, bringing the dozing blade between the width of the track shoes. Therefore, the dozer is easy to transport and always ready to go to a new job-site.

Versatility

During the operation the blade can be angled between -25° and 25°, so the dozer can be used for a wider range of applications. The newly designed blade attachment, using a large diameter ball, ensures a longer ball life and superior grading ability. The top of the ball is protected by a special rubber seal that prevents foreign materials from entering into the ball joint, thus increasing its lifetime. High quality steel is used for the blade in combination with Komatsu segmented cutting edges.

Outstanding stability

The large ground contact area created by the long tracks together with a wide track gauges combine with a low center of gravity to make the D41-6 a stable and well balanced machine that can perform precise grading work even on rough or inclined terrain.

Exceptional blade visibility

The slim engine hood and well located operator seat provide excellent visibility of the blade.

This greatly increases grading efficiency and operator performance. Finish grading and rough grading can both be performed easily, drastically reducing cycle times.

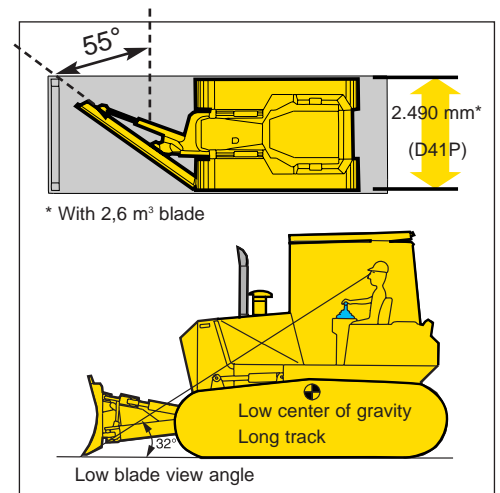

Active steering system

The steering system of the D41-6 uses caliper actuators for the oil cooled steering and brake single disc system. The ergonomic joystick lever with the PPC (proportional pressure control) valve provides a proportional pressure to the steering and brake system. As a result the D41-6 can make smooth turns with still power transfer to both tracks. So the dozing performance is far superior to standard clutch and brake systems.

The oil lubricated "Caliper and single disc system" is maintenance free, so a long lifetime is guaranteed.



UNDERCARRIAGE

Low drive and long track undercarriage

Komatsu's design is extraordinarily tough and offers excellent grading ability and stability.

Tough undercarriage

Large link height, pins and bushing diameter and double-flanged track rollers ensures extended life of undercarriage. The newly designed sprocket increases lifetime of the heavy-duty undercarriage of the D41E-version and the heavy-duty abrasion resistant D41P-version.

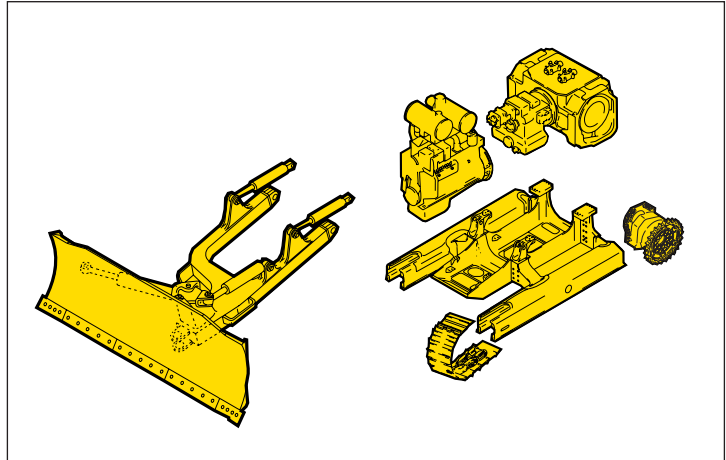

Flat bottom frame

A flat bottom frame and the monocoque track frames provide good maneuverability in muddy terrain by preventing mud from building up under the frame.

Modular designed power train units

The modular design allows easy removal and installation of any individual unit for shorter downtime. Each modul is sealed off individualy, preventing oil leakage and oil contamination during operation and maintenance.

Durability

Because fewer components mean greater reliability, we've designed a simple hull frame made of a thick, single plate. Track frames have a large-section construction for maximum rigidity. Even the box-section construction of the blade back beam is reinforced, all with durability in mind.



MAINTENANCE FEATURES

Reversible hydrostatic driven cooling fan

If the machine is operating in adverse conditions, the operator can reverse the hydraulic driven engine cooling fan from inside the cab by turning on a switch on the control panel, facilitating cleaning of the radiator fins.

Gull-wing engine side covers

Gull-wing engine side covers open 140° by assistance of a gas-spring cylinder. Both the engine and the auxiliary components can be checked easily.

Wet, single-disc brakes

Wet, single-disc brakes eliminate brake-disc adjustments for maintenance-free operation.



Reservoir



A radiator coolant reservoir makes it easier to check the coolant level and eliminates frequent refilling.

Test ports



Oil pressure test ports for the power train are centralized on the right hand side of the operator platform for easy access.

Electronic monitoring system

An electronic monitoring system prevents minor problems from developing into major ones. All meters and gauges are controlled by a microcomputer, which provides a wide range of machine data.

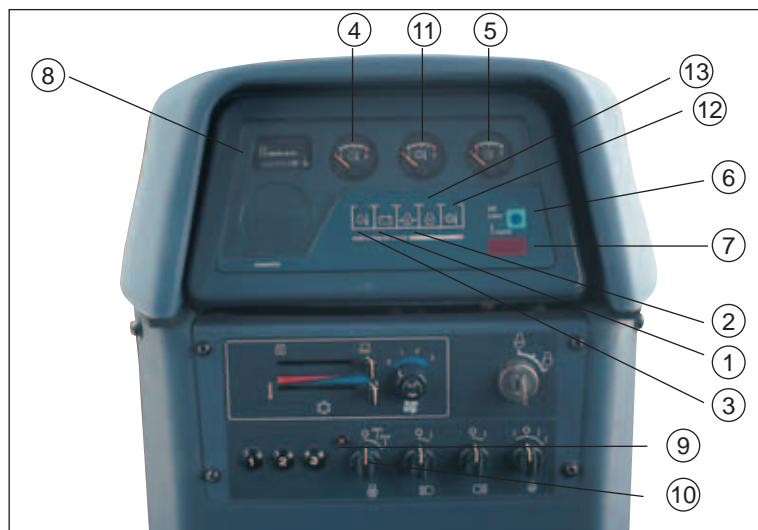

- ① Charge lamp
- ② Engine oil pressure caution lamp
- ③ Engine water temperature caution lamp
- ④ Engine water temperature gauge
- ⑤ Fuel gauge
- ⑥ Monitor caution cancel switch
- ⑦ Monitor caution lamp
- ⑧ Service meter
- ⑨ Fan rotation selector switch
- ⑩ Fan operation confirmation lamp
- ⑪ Transmission oil gauge
- ⑫ Transmission oil temperature caution lamp
- ⑬ Glow signal lamp

SPECIFICATIONS



ENGINE

Model Komatsu SA6D102E-2A
 Type 4-stroke cycle, water-cooled, emissionized, direct injection, turbocharged, aftercooled engine
 Number of cylinders 6
 Bore 102 mm
 Stroke 120 mm
 Piston displacement 5,88 ltr
 Net flywheel horsepower*
 SAEJ1349 82 kW (110 HP) @ 2.300 rpm
 DIN6270 82 kW (112 PS) @ 2.300 rpm
 Net maximum torque 47 kg•m @ 1.300 rpm

Direct injection fuel system. All-speed mechanical governor. Forced lubrication driven by gear pump. Full-flow for lube purification. Dry-type air cleaner with automatic dust evacuator and dust indicator. 5,5 kW/24V electrical starter motor. 60 A/24 V alternator. 100 Ah/2 x 12 V batteries.

*Net flywheel horsepower output for standard engine (SAE J1349) including air cleaner, alternator (not charging), water pump, lubricating oil pump, fuel pump, muffler, and fan.



HYDROSTATIC TRANSMISSION

Komatsu's unique HYDROSHIFT transmission with planetary gears is hydraulically controlled. Efficient power flow and simplified direction and speed changes. Joystick control of gears (3 forward and 3 reverse), directional and steering changes. Gearshift lock lever and neutral safety switch prevent machine from accidental starts.

Travel speed	Forward	Reverse
1st	2,4 km/h	3,0 km/h
2nd	4,4 km/h	5,5 km/h
3rd	7,6 km/h	9,4 km/h



STEERING SYSTEM

Joystick controls for all directional movements. Pushing the joystick forward results in forward machine travel, while pulling it backwards reverses the machine. Simply tilt the joystick to the left to make a left turn. Tilt it to the right for a right turn.

Wet, single-disc steering clutches are hydraulically actuated. A PPC valve integrated into steering circuit facilitates smooth, shockless steering control.

Minimum turning radius:
 D41E-6 2,4 m
 D41P-6 2,6 m
 As measured by track marks on ground.



ENVIRONMENT

Engine emissions fully complies with the European Stage 2 exhaust emission regulations
 Noise levels
 LwA noise outside (2000/14/EC-dynamic values) 108 dBA
 LpA Operator ear noise (ISO 6396) (dynamic) 81 dBA



FINAL DRIVE

Spur gear single-reduction, final drives increase tractive effort. Bolt-on sprockets are for easy in-the-field replacement.



UNDERCARRIAGE

Suspension Rigid type
 Track roller frame Monocoque, box section, high-tensile-strength steel durable construction
 Number of carrier rollers (each side) 1
 Lubricated tracks:
 Unique dust seals for preventing entry of foreign abrasive material into the pin-to-bushing clearance, for extended lifetime.
 Track tension easily adjusted with a grease gun.

	D41E-6	D41P-6
Number of track rollers (each side)	6	7
Number of shoes (each side)	41	44
Grouser height	53 mm	53 mm
Shoe width (standard)	560 mm	700 mm
Ground contact area	27.832 cm ²	38.430 cm ²
Ground pressure (Tractor)	0,40 kgf/cm ²	0,30 kgf/cm ²
Track gauge	1.790 mm	1.790 mm
Length of track on ground	2.485 mm	2.745 mm



COOLANT AND LUBRICANT CAPACITY (REFILL)

Coolant 28 ltr
 Fuel tank 250 ltr
 Engine oil 19 ltr
 Damper 1,1 ltr
 Transmission 19 ltr
 Bevel gear and steering system 74 ltr
 Final drive (each side) 13 ltr



OPERATING WEIGHT (APPROXIMATE)

Operating weight:
 Including power angle tilt dozer, ROPS canopy, FOPS cab, operator, standard equipment, rated capacity of lubricant, coolant, and full fuel tank.
 D41E-6 11.380 kg
 D41P-6 11.880 kg

SPECIFICATIONS



DIMENSIONS

	D41E-6	D41P-6
A	4.880 mm	4.880 mm
B	2.300 mm	2.490 mm
C	2.900 mm	2.900 mm
D	2.675 mm	2.675 mm
E	1.790 mm	1.790 mm
F	2.485 mm	2.745 mm
G	525 mm	525 mm
H	53 mm	53 mm
I	1.830 mm	1.830 mm
J	1.824 mm	1.824 mm

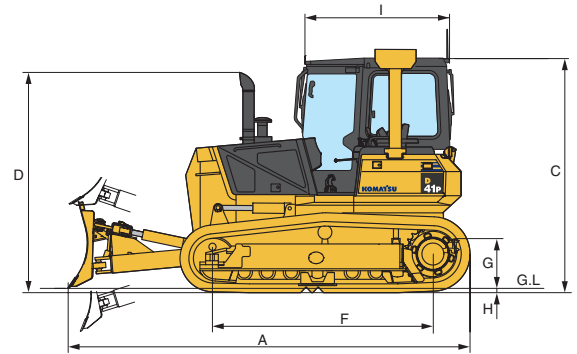
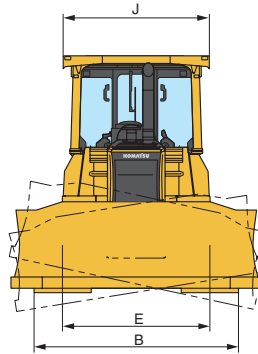

Ground clearance: 365 mm



HYDRAULIC SYSTEM

	D41E		D41P	
	2,6 m ³	2,9 m ³	2,6 m ³	2,9 m ³ *
Blade capacity (SAE)	2,6 m ³	2,9 m ³	2,6 m ³	2,9 m ³ *
A	2.395	2.485	2.490	2.990
B	1.245	1.335	1.245	1.395
C	1.255	1.395	1.255	-
D	1.520	1.655	1.520	1.655
Transport width	2.395	2.485	2.490	2.990

* When equipped with the 3.350 mm width blade, maximum blade angle is 30 degrees and overall width is 2.990 mm.

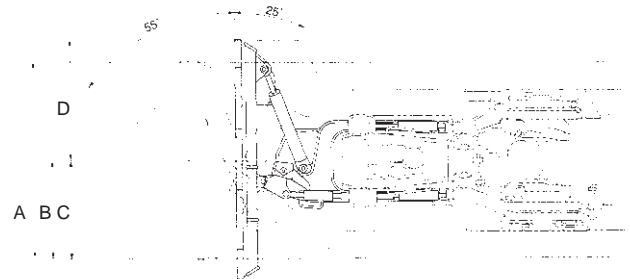

HYDRAULIC SYSTEM

Closed-center Load Sensing System (CLSS) designed for precise and responsive control and for efficient simultaneous operation.

Hydraulic control unit:

All spool control valves externally mounted beside the hydraulic tank. Gear-type hydraulic pump with capacity (discharge flow) of **86 ltr/min** at rated engine rpm.

Relief valve setting 20,6 MPa / 210 kg/cm²

Hydraulic cylinders Double-acting, piston type

	Number of cylinders	Bore
Blade lift	2	105 mm
Blade tilt	1	110 mm
Blade angle	1	130 mm

Hydraulic oil capacity (refilling):

Power angle tilt dozer 44,0 ltr

Control valves:

3-Spool control valve for power angle tilt dozer.

Positions:

Blade lift Raise, hold, lower, and float

Blade tilt Right, hold, and left

Blade angle Right, hold, and left

Additional control valve required for ripper.

Positions:

Ripper lift Raise, hold, and lower

SPECIFICATIONS



DOZER EQUIPMENT (POWER ANGLE TILT DOZER)

D41-6 uses box construction of the back plate while using high-tensile-strength steel in moldboard to ensure extended service. Hydraulic hoses for blade angling and tilting are covered with steel plates for protection from damage.

	Overall Length With Dozer	Blade Capacity (SAE)	Blade Width x Height	Max. Lift Above Ground	Maximum Below Ground	Tilt Adjustment		Blade Angle		Additional Weight	
						L.H.	R.H.	L.H.	R.H.	Dozer equipment	Hydraulic control unit
D41E-6 Power Angle Tilt Dozer	4.880 mm	2,6 m ³	3.045 mm x 1.060 mm	1.010 mm	490 mm	485 mm	645 mm	55°	25°	1.580 kg	220 kg
D41E-6 Power Angle Tilt Dozer	4.880 mm	2,9 m ³	3.350 mm x 1.060 mm	1.010 mm	490 mm	530 mm	710 mm	55°	25°	1.660 kg	220 kg
D41P-6 Power Angle Tilt Dozer	4.870 mm	2,6 m ³	3.045 mm x 1.060 mm	1.010 mm	490 mm	485 mm	645 mm	55°	25°	1.580 kg	220 kg
*D41P-6 Power Angle Tilt Dozer	4.870 mm	2,9 m ³	3.350 mm x 1.060 mm	1.010 mm	490 mm	530 mm	710 mm	30°	25°	1.660 kg	220 kg

* When equipped with the 3.350 mm width blade, maximum blade angle is 30 degrees and overall width is 2.990 mm.



CRAWLER DOZER



STANDARD EQUIPMENT

CAB

- Decelerator pedal
- Electronic instrument monitor panel
- Fenders
- Air conditioner
- High mount footrest
- Rear window defroster
- Seat belt, retractable
- Mono-lever steering with PPC
- Suspension seat (Fabric/reclining)
- Inside cab rearview mirror

UNDERCARRIAGE

- Track roller guard, centre and end section
- Track shoe assembly – Sealed and lubricated track

- 560 mm single grouser heavy-duty shoes (D41E)
- 700 mm single grouser heavy-duty, abrasion resistant shoes (D41P)

ENGINE RELATED PARTS

- Air cleaner, double element with dust indicator
- Cooling fan, hydrostatic driven
- Engine hood and gull-wing side covers
- Intake pipe with precleaner
- Locks, filler caps and covers
- Muffler with curved exhaust pipe
- Radiator reserve tank
- Rear cover
- Water separator

ATTACHMENTS

- Backup alarm
- Hitch
- Front pull hook
- Underguards, oil pan and transmission

ELECTRICITY

- Starting motor 5,5 kW/24V
- Batteries 100 Ah/2 x 12 V
- Alternator 60 A, 24 V
- Lighting system (includes 2 front, 1 rear)

DOZING EQUIPMENT

- Power angle tilt dozer assembly, inside frame (2,6 m³) (D41E/P-6)

ROPS FOR CAB

- Additional weight 220 kg
- Meets ISO 3471, SAE J1040 APR88 ROPS standards
- Dimensions:
 - Length: 530 mm
 - Width: 1.670 mm
 - Overall height: 2.900 mm

STEEL CAB

- Additional weight 490 kg
- Meets ISO 3449 FOPS standards
- All-weather, enclosed pressurized cab
- Dimensions:
 - Length: 1.760 mm
 - Width: 1.380 mm
 - Height: 1.590 mm
 - Overall height: 2.780 mm

OPTIONAL EQUIPMENT

RIPPING EQUIPMENT

- Hydraulics for ripper (D41E)
- Multi-shank ripper (D41E)
 - Additional weight (including hydraulic control unit): 810 kg
 - Beam length: 1.555 mm

- Maximum digging depth: 510 mm
- Maximum lift above ground: 350 mm

DOZING EQUIPMENT

- Light working, cab additional
- Power Angle Tilt dozer assembly, inside frame and wide blade (2,9 m³) (D41 E/P-6)

UNDERCARRIAGE

- Track guard, full length

KOMATSU

**Komatsu Europe
International NV**

Mechelsesteenweg 586
B-1800 VILVOORDE (BELGIUM)
Tel. +32-2-255 24 11
Fax +32-2-252 19 81
www: komatsueurope.com